

MathsWatch Worksheets

FOUNDATION

Questions

Clip No	Name of clip	Tier	Grades	Pg No
1	Place value	F	G to E	1
2	Ordering Decimals	F	G to E	2
3	Round to nearest 10, 100, etc	F	G to E	3
4	Reading scales	F	G to E	4
5	Multiply or divide by powers of 10	F	G to E	5
6	Negatives in real life	F	G to E	6
7	Multiplication and division with negatives	F	G to E	7
8	Fraction of an amount	F	G to E	8
9	Square and Cube Numbers	F	G to E	9
10	Fractions, Decimals and Percentages	F	G to E	10
11	Money questions	F	G to E	11
12	Shading fractions of rectangles	F	G to E	12
13	Ordering Fractions, Decimals & Percentages	F	G to E	13
14	Estimating answers	F	G to E	14
15	Place value when multiplying	F	G to E	15
16	Addition and subtraction	F	G to E	16
17	Long multiplication	F	G to E	17
18	Long division	F	G to E	18
19	Multiplication & Division with Decimals	F	G to E	19
20	Decimal places and significant figures	F	G to E	20
21	Half way points	F	G to E	21
22	Reciprocals	F	G to E	22
23	Proportion	F	G to E	23
24	Distance tables	F	G to E	24
25	Timetables	F	G to E	25
26	Powers	F	G to E	26
27	Line Graphs	F	G to E	27
28	Coordinates	F	G to E	28
29	Number Sequences	F	G to E	29
30	Number Machines	F	G to E	30
31	Angles	F	G to E	31
32	Congruent and Similar Shapes	F	G to E	32
33	Area and Perimeter	F	G to E	33
34	Volume of cuboids	F	G to E	34
35	Converting Metric Measures	F	G to E	35
36	Triangles, Quadrilaterals & Other Polygons	F	G to E	36
37	Names of solids	F	G to E	37
38	Tessellations	F	G to E	38
39	Isometric drawing	F	G to E	39
40	The probability scale	F	G to E	40
41	The averages	F	G to E	41
42	Pictograms	F	G to E	42
43	Conversion graphs	F	G to E	43

Clip No	Name of clip	Tier	Grades	Pg No
44	Factors, Multiples and Primes	F and H	D	44
45	Evaluate powers	F and H	D	45
46	Understand squares, cubes, roots	F and H	D	45
47	Equivalent fractions	F and H	D	46
48	Simplification of fractions	F and H	D	46
49	Put fractions in order	F and H	D	46
50	Value for money	F and H	D	47
51	Percentage of an amount with a calculator	F and H	D	48
52	Percentage of an amount without a calculator	F and H	D	48
53	Change to a percentage with a calculator	F and H	D	49
54	Change to a percentage without a calculator	F and H	D	49
55	Find a fraction of an amount	F and H	D	50
56	Addition and subtraction of fractions	F and H	D	51
57	Multiply and divide fractions	F and H	D	52
58	Change fractions to decimals	F and H	D	53
59	BODMAS	F and H	D	54
60	Long Multiplication of Decimals	F and H	D	55
61	Ratio	F and H	D	56
62	Recipe type ratio questions	F and H	D	57
63	Hard calculator questions	F and H	D	58
64	Real-life money questions	F and H	D	59
65	Generate a sequence from the nth term	F and H	D	60
66	Substitution	F and H	D	61
67	Parallel lines	F and H	D	62
68	Angle sum of a triangle	F and H	D	63-64
69	Properties of special triangles	F and H	D	63-64
70	Finding angles of regular polygons	F and H	D	65
71	Area of circle	F and H	D	66
72	Circumference of circle	F and H	D	67
73	Area of compound shapes	F and H	D	68
74	Rotations	F and H	D	69
75	Reflections	F and H	D	70
76	Enlargements	F and H	D	71
77	Translations	F and H	D	72
78	Find the mid-point of a line	F and H	D	73
79	Measuring and drawing angles	F and H	D	74
80	Drawing triangles	F and H	D	75
81	Plans and elevations	F and H	D	76
82	Nets	F and H	D	77
83	Symmetries	F and H	D	78
84	Questionnaires and data collection	F and H	D	79
85	Two-way tables	F and H	D	80
86	Pie charts	F and H	D	81
87	Scatter graphs	F and H	D	82
88	Frequency diagrams	F and H	D	83
89	Stem and leaf diagrams	F and H	D	84
90	List of outcomes	F and H	D	85
91	Mutually Exclusive Events	F and H	D	85

Clip No	Name of clip	Tier	Grades	Pg No
92	Overview of percentages	F and H	C	86
93	Increase/decrease by a percentage	F and H	C	87
94	Ratio	F and H	C	88
95	Products of prime factors	F and H	C	89
96	LCM and HCF	F and H	C	89
97	Standard form	F and H	C	90
98	Recurring decimals into fractions	F and H	C	91
99	Four rules of negatives	F and H	C	92
100	Division by 2-digit decimals	F and H	C	92
101	Estimate answers	F and H	C	93
102	Algebraic simplification	F and H	C	94
103	Expanding & simplifying brackets	F and H	C	95
104	Factorisation	F and H	C	96
105	Solving equations	F and H	C	97
106	Forming equations	F and H	C	98
107	Changing the subject of a formula	F and H	C	99
108	Inequalities	F and H	C	100
109	Solving inequalities	F and H	C	101
110	Trial and improvement	F and H	C	102
111	Index Notation for Multiplication & Division	F and H	C	103
112	Find the Nth term	F and H	C	104
113	Drawing straight line graphs	F and H	C	105
114	Equation of a straight line	F and H	C	106
115	Simultaneous Equations Graphs	F and H	C	107
116	Drawing Quadratic Graphs	F and H	C	108
117	Real-life Graphs	F and H	C	109
118	Pythagoras' Theorem	F and H	C	110
119	Pythagoras - line on a graph	F and H	C	111
120	3-D coordinates	F and H	C	112
121	Surface area of cuboids	F and H	C	113
122	Volume of a prism	F and H	C	114
123	Similar shapes	F and H	C	115
124	Dimensions	F and H	C	116
125	Bounds	F and H	C	117
126	Compound measures	F and H	C	118
127	Bisecting a line	F and H	C	119
128	Drawing a perpendicular to a line	F and H	C	120
129	Bisecting an angle	F and H	C	121
130	Loci	F and H	C	122-123
131	Bearings	F and H	C	124
132	Experimental probabilities	F and H	C	125
133	Averages from a table	F and H	C	126
134	Questionnaires	F and H	C	127

Place Value

1 000 000	100 000	10 000	1 000	100	10	1
-----------	---------	--------	-------	-----	----	---

- 1)
 - a) Write the number forty five thousand, two hundred and seventy three in figures.
 - b) Write the number five thousand, one hundred and three in figures.
 - c) Write the number three hundred thousand, seven hundred and ninety one in figures.
 - d) Write the number two and a half million in figures.
 - e) Write the number one and three quarter million in figures.

- 2) Write the following numbers in words
 - a) 1 250
 - b) 3 502
 - c) 72 067
 - d) 192 040
 - e) 30 000 000

- 3)
 - a) Write down the value of the 7 in the number 3752.
 - b) Write down the value of the 6 in the number 56025.
 - c) Write down the value of the 2 in the number 99723.
 - d) Write down the value of the 5 in the number 258610.
 - e) Write down the value of the 2 in the number 1253549.

Put these numbers in order, starting with the smallest:

- 1) 74, 57, 38, 8, 61
- 2) 39, 84, 11, 128, 24
- 3) 76, 102, 12, 140, 73
- 4) 3.1, 31, 1.3, 13, 1.03
- 5) 0.321, 0.312, 1.04, 1.23
- 6) 0.34, 0.047, 0.4, 0.43, 0.403
- 7) 0.79, 0.709, 0.97, 0.792
- 8) 2.71, 2.074, 2.071, 2.701
- 9) 0.875, 0.88, 0.0885, 0.008, 0.11
- 10) 3, -2, -7, 10, -1
- 11) -3, -11, 1, -5, 7
- 12) -4, 6, 0, -6, -1

1) Round these numbers to the nearest 10:

- a) 26
- b) 62
- c) 75
- d) 231
- e) 797
- f) 5842
- g) 9875
- h) 13758

2) Round these numbers to the nearest 100:

- a) 78
- b) 223
- c) 549
- d) 1450
- e) 1382
- f) 4537
- g) 9193
- h) 17625

3) Round these numbers to the nearest 1000:

- a) 850
- b) 1455
- c) 3230
- d) 7500
- e) 8455
- f) 9690
- g) 12390
- h) 28910

Reading Scales

1) What is the reading on each of these scales?

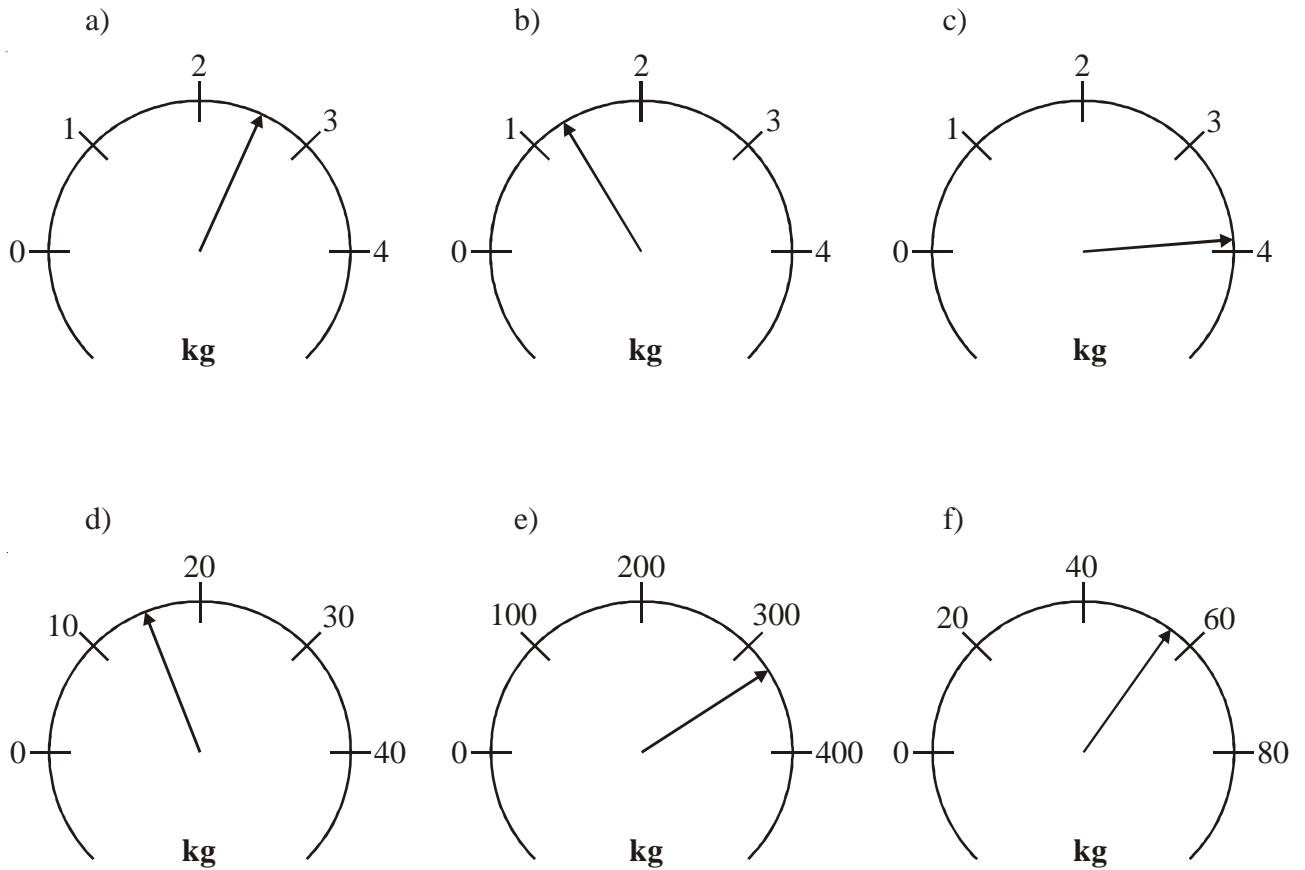

2) This scale shows degrees Centigrade.

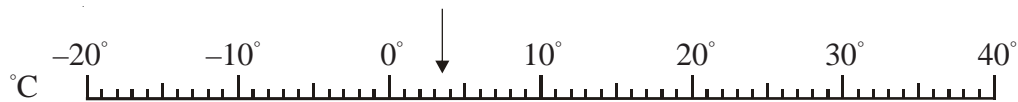

- What temperature is the arrow pointing to?
- Draw an arrow which points to -17°C

3) This is a diagram for converting gallons to litres.

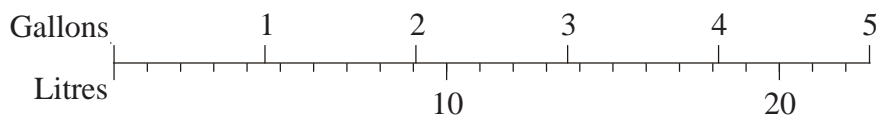

Use the diagram to convert

- 3 gallons to litres.
- 4.5 gallons to litres.
- 6 litres to gallons.

1) Multiply the following numbers by 10, 100 and 1000:

		$\times 10$	$\times 100$	$\times 1000$
<i>e.g.</i>	21	210	2100	21000
	9			
	63			
	845			
	3.65			
	0.4			
	1.324			

2) Divide the following numbers by 10, 100 and 1000:

		$\div 10$	$\div 100$	$\div 1000$
<i>e.g.</i>	21	2.1	0.21	0.021
	9			
	63			
	845			
	3.65			
	0.4			
	1.324			

3) Work out the following:

$$3 \times 100 =$$

$$65 \times 10 =$$

$$17 \div 10 =$$

$$359 \times 10 =$$

$$0.5 \div 100 =$$

$$2.3 \times 1000 =$$

$$42 \div 100 =$$

$$3582 \div 100 =$$

$$0.9 \times 10 =$$

$$3.645 \times 100 =$$

$$88 \div 1000 =$$

$$39.62 \times 1000 =$$

- 1) At midnight, the temperature was -7°C .
By 7am the next morning, the temperature had increased by 6°C .
a) Work out the temperature at 7am the next morning.

At midday, the temperature was 3°C .

- b) Work out the difference between the temperature at midday and the temperature at midnight.
c) Work out the temperature which is halfway between -7°C and 3°C .
- 2) The table below gives the temperature recorded on 25th December of 7 cities across the world.

City	Edinburgh	London	New York	Moscow	Paris	Rome	Cairo
Temperature	-6°C	0°C	-15°C	-23°C	3°C	5°C	18°C

- a) Which city recorded the lowest temperature?
b) What is the difference in temperature between New York and Paris?
c) What is the difference in temperature between Cairo and Edinburgh?
d) The temperature in Madrid was 9°C lower than in Rome.
What was the temperature in Madrid?
e) The temperature in Mexico was 6°C higher than in New York.
What was the temperature in Mexico?
- 3) The table shows the temperature on the surface of each of five planets.

Planet	Temperature
Venus	210°C
Jupiter	-150°C
Saturn	-180°C
Neptune	-210°C
Pluto	-230°C

- a) Work out the difference in temperature between Jupiter and Pluto.
b) Work out the difference in temperature between Venus and Saturn.
c) Which planet has a temperature 30°C lower than Saturn?

The temperature on Mars is 90°C higher than the temperature on Jupiter.

- d) Work out the temperature on Mars.

Multiplication & Division with Negatives

Work out the following:

1) $-3 \times 6 =$

2) $4 \times 2 =$

3) $10 \div -2 =$

4) $-6 \div -3 =$

5) $-5 \times -7 =$

6) $7 \times -3 =$

7) $12 \div 4 =$

8) $-24 \div 6 =$

9) $-8 \times 2 =$

10) $-9 \div 3 =$

11) $4 \div -1 =$

12) $-3 \times -9 =$

13) $-70 \div -7 =$

14) $11 \times -6 =$

15) $4 \times -3 \times 2 =$

16) $-5 \times 2 \times -4 =$

17) $4 \times 5 \div -2 =$

18) $-8 \div -2 \times -6 =$

19) $-2 \times -3 \times -4 =$

20) $8 \div -2 \times -6 =$

Fraction of an Amount

1) Work out the following:

a) $\frac{1}{2}$ of £10 b) $\frac{1}{3}$ of £9 c) $\frac{1}{5}$ of £25 d) $\frac{1}{2}$ of 24kg

e) $\frac{1}{4}$ of 36cm f) $\frac{1}{6}$ of 42kg g) $\frac{1}{8}$ of 48kg h) $\frac{1}{11}$ of £66

i) $\frac{1}{9}$ of 90km j) $\frac{1}{7}$ of £28 k) $\frac{1}{5}$ of 125kg l) $\frac{1}{6}$ of 240km

2) Work out the following:

a) $\frac{1}{4}$ of 20 b) $\frac{3}{4}$ of 20 c) $\frac{1}{3}$ of 21 d) $\frac{2}{3}$ of 21 e) $\frac{3}{4}$ of 44

f) $\frac{2}{3}$ of 24 g) $\frac{3}{5}$ of 15 h) $\frac{3}{4}$ of 36 i) $\frac{7}{9}$ of 81 j) $\frac{5}{7}$ of 56

k) $\frac{3}{10}$ of 50 l) $\frac{6}{11}$ of 33 m) $\frac{1}{4}$ of 14 n) $\frac{3}{4}$ of 14 o) $\frac{3}{8}$ of 20

3) The highest possible mark for a Maths test was 64.

Dora got $\frac{7}{8}$ of the full marks.

How many marks did she get?

4) At MathsWatch School there are 1500 students.

$\frac{7}{15}$ of these students are male.

a) What fraction of students are female?

b) How many are male?

c) How many are female?

Square and Cube Numbers

1)

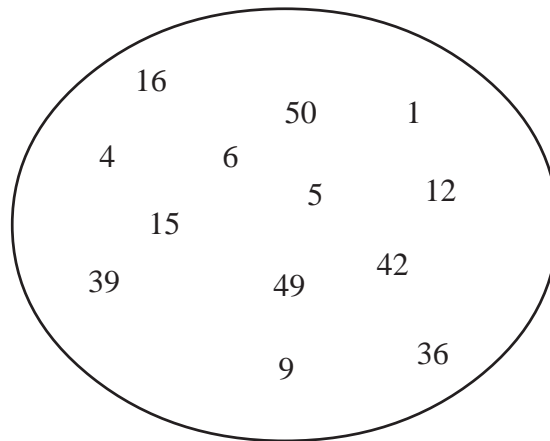

- a) In the numbers, above, find six of the first seven square numbers.
b) Which of the first seven square numbers is missing?

2) Work out the following:

- a) 10^2 b) 9^2 c) $7^2 + 3^2$ d) $8^2 - 2^2$

3) For each pair of numbers, below, there is just one square number that lies between them. In each case, write the square number:

- a) 7 15 b) 21 29 c) 72 96 d) 130 156

4) Work out the following:

- a) $\sqrt{25}$ b) $\sqrt{81}$ c) $\sqrt{16} + 6^2$

5) The first cube number is $1^3 = 1$

Write out the 2nd, 3rd, 4th and 10th cube numbers.

6) Work out the following:

- a) $1^3 + 3^3$ b) $10^3 + 5^3$

7) Work out the following:

- a) $3^3 + 6^2$ b) $10^3 + \sqrt{100}$

8) Work out what should go in the boxes:

- a) $\sqrt{\square} = 6$ b) $\sqrt{\square} = 8$

1. Write the following fractions as decimals and percentages:

eg. $\frac{1}{10} \xrightarrow{1 \div 10} 0.1 \xrightarrow{0.1 \times 100} 10\%$

a) $\frac{3}{10} =$

b) $\frac{1}{5} =$

c) $\frac{2}{5} =$

d) $\frac{1}{4} =$

e) $\frac{3}{4} =$

f) $\frac{1}{2} =$

g) $\frac{1}{3} =$

2. Fill in the blanks in the table below:

Fraction	Decimal	Percentage
$\frac{6}{10}$		
	0.2	
	0.9	
		40%
		25%
	0. $\dot{3}$	
		70%

- 1) Bill buys 3 melons at £1.09 each.
- a) How much does he spend?
- b) How much change does he get from £5?

- 2) Jenny is taking her family to the cinema.
Jenny pays for 1 adult and 3 children.
- a) How much does she spend?
- b) How much change does she get from £20?

Cinema

Adult: £6.50

Child: £4.00

- 3) Bob is paid £7 per hour.
- a) Last monday Bob worked for 8 hours
Work out his pay for that day.
- b) Yesterday Bob was paid £42.
Work out how many hours Bob worked.

- 4) Complete this bill.

1½ kg of carrots at 40p per kg = £.....

3 kg of potatoes at 52p per kg = £.....

..... boxes of tea bags at 90p each = £1.80

4 packs of yogurts at each = £4.80

Total = £.....

Shading Fractions

1) What fraction of each of the following shapes is shaded?

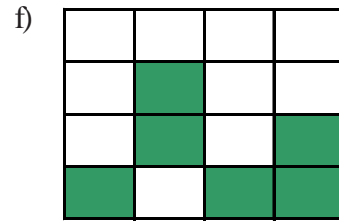
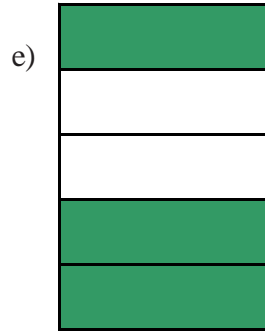
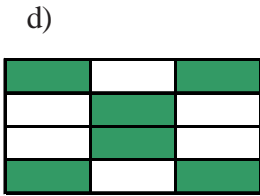
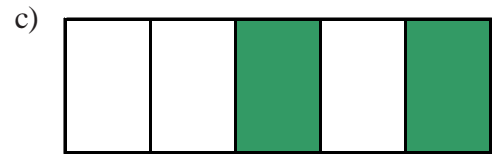
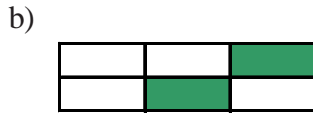
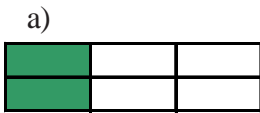

2) Shade the given fraction in the following grids.

$$\frac{3}{5}$$

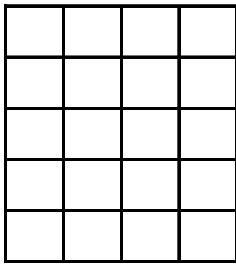

$$\frac{1}{4}$$

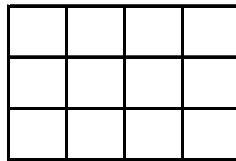

$$\frac{4}{6}$$

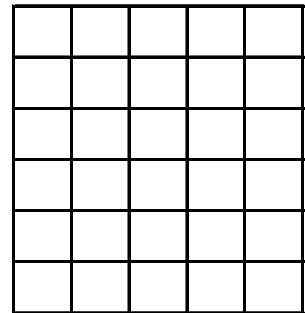

3) Which of these fractions is the smallest? $\frac{5}{6}$ or $\frac{7}{9}$ (use the grids to help)

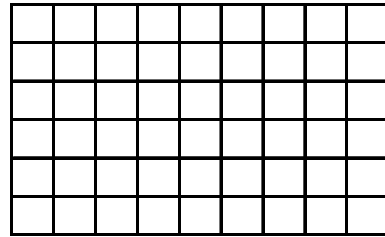
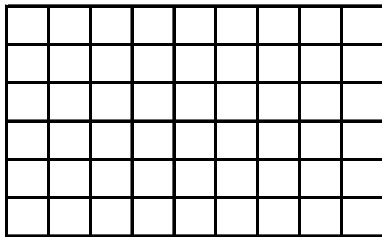

4) Which of these fractions is the largest? $\frac{2}{7}$ or $\frac{1}{3}$ (you must show your working)

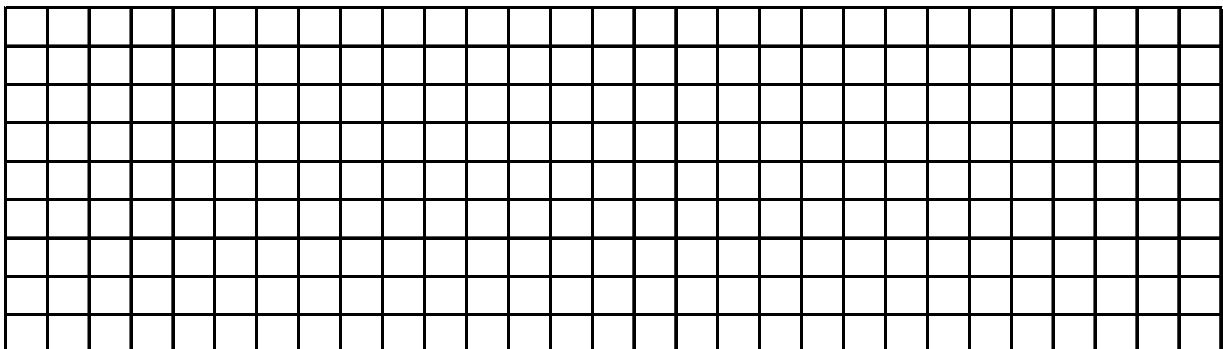

1. Change these fractions to decimals

eg. $\frac{1}{5} \xrightarrow{1 \div 5} 0.2$

a) $\frac{3}{5}$

b) $\frac{4}{5}$

c) $\frac{1}{4}$

d) $\frac{3}{4}$

e) $\frac{1}{3}$

f) $\frac{2}{3}$

2. Change these percentages to decimals

eg. $52\% \xrightarrow{52 \div 100} 0.52$

a) 63%

b) 8%

c) 59%

d) 81%

e) 28.5%

f) 6.5%

3. Write the following numbers in order of size (smallest to largest)

a) 0.61

$\frac{2}{3}$

59%

0.55

$\frac{3}{5}$

b) 81%

0.78

$\frac{4}{5}$

$\frac{3}{4}$

0.805

c) $\frac{1}{3}$

0.3

$\frac{1}{4}$

28.5%

0.32

d) 0.23

21%

$\frac{1}{5}$

$\frac{22}{100}$

19.2%

e) 1%

0.012

$\frac{3}{100}$

0.021

$\frac{1}{40}$

1) Work out an estimate

eg. $17 \times 193 \longrightarrow 20 \times 200 = 4000$

a) 12×304

c) 231×56

b) 38×72

d) 773×13

2) Work out an estimate

eg. $4.7 \times 54 \longrightarrow 5 \times 50 = 250$

a) 3.8×52

c) 9.6×265

b) 7.9×103

d) 512×2.4

3) Work out an estimate

eg. $37 \div 12 \longrightarrow 40 \div 10 = 4$

a) $122 \div 53$

c) $\frac{341}{28}$

b) $372 \div 44$

d) $\frac{109}{96}$

4) Work out an estimate

eg. $37 \div 1.2 \longrightarrow 40 \div 1 = 40$

a) $68 \div 1.7$

c) $\frac{253}{4.6}$

b) $37 \div 7.9$

d) $\frac{96}{10.4}$

5) Work out an estimate

eg. $\frac{62 \times 28}{89} \longrightarrow \frac{60 \times 30}{90} = \frac{1800}{90}$

a) $\frac{45 \times 21}{14}$

c) $\frac{42 \times 53}{2.2}$

b) $\frac{76 \times 17}{42}$

d) $\frac{33 \times 61}{8.7}$

- 1) Use the information that $23 \times 68 = 1564$
work out the value of:
- a) 2.3×68
 - b) 2.3×6.8
 - c) 0.23×68
 - d) 2.3×0.68
 - e) 230×68
 - f) 230×6.8
 - g) 2300×680
 - h) $1564 \div 23$
 - i) $1564 \div 2.3$
 - j) $15640 \div 23$
- 2) Using the information that $416 \times 35 = 14560$
work out the value of:
- a) 4.16×35
 - b) 41.6×0.35
 - c) 41600×350
 - d) 0.416×350
 - e) 4160×0.035
 - f) 41.6×350000
 - g) 0.00416×0.0035
 - h) $14560 \div 3.5$
 - i) $145.6 \div 4.16$
 - j) $1.456 \div 0.35$
- 3) If $78 \div 2.5 = 31.2$, what do you have to divide 78 by to get an answer of 0.312?
- 4) If $812 \times 2.9 = 2354.8$, what do you have to multiply 8.12 by to get an answer of 23548?

1) a) $\begin{array}{r} 42 \\ +26 \\ \hline \end{array}$ b) $\begin{array}{r} 57 \\ +38 \\ \hline \end{array}$ c) $\begin{array}{r} 96 \\ +75 \\ \hline \end{array}$

2) a) $\begin{array}{r} 637 \\ +961 \\ \hline \end{array}$ b) $\begin{array}{r} 983 \\ +442 \\ \hline \end{array}$ c) $\begin{array}{r} 969 \\ +758 \\ \hline \end{array}$

3) a) $452 + 38$ b) $147 + 763$ c) $813 + 431 + 38$

- 4) There were two exhibitions at the NEC one Sunday.
3816 people went to one of the exhibitions and 13427 people went to the other exhibition.
How many people went to the NEC, in total, on the Sunday?

5) a) $2.6 + 1.2$ b) $2.74 + 6.81$ c) $45.36 + 6.81$

6) a) $23 + 1.5$ b) $13.6 + 38$ c) $13.2 + 17.82$

7) a) $\begin{array}{r} 78 \\ -42 \\ \hline \end{array}$ b) $\begin{array}{r} 74 \\ -26 \\ \hline \end{array}$ c) $\begin{array}{r} 62 \\ -39 \\ \hline \end{array}$

8) a) $\begin{array}{r} 485 \\ -291 \\ \hline \end{array}$ b) $\begin{array}{r} 773 \\ -486 \\ \hline \end{array}$ c) $\begin{array}{r} 100 \\ -34 \\ \hline \end{array}$

9) a) $653 - 48$ b) $362 - 183$ c) $2000 - 461$

- 10) There were two films showing at a cinema one Saturday.
One of the films was shown in a large room and the other was in a smaller room.
The film in the larger room was watched by a total of 3562 people.
The film in the smaller room was watched by 1671 people.
How many more people saw the film in the larger room?

11) a) $782 + 426 - 278$ b) $8162 + 1149 - 799$

- 1) Work out
 - a) 13×18
 - b) 135×27
 - c) 116×41
 - d) 264×43
 - e) 326×24
 - f) 281×59
 - g) 286×48
 - h) 428×34
 - i) 461×45
- 2) “MathsWatch Travel” has 36 coaches.
Each of these coaches can carry 53 passengers.
How many passengers in total can all the coaches carry?
- 3) “MathsWatch Tours” has a plane that will carry 47 passengers.
To fly from Manchester to Lyon, each passenger pays £65
Work out the total amount that the passengers pay.
- 4) A litre of petrol costs 86p.
Work out the cost of 35 litres of petrol.
Give your answer in pounds (£).
- 5) Last week, MathsWatch posted 439 parcels.
Each parcel needed a 97p stamp.
Work out the total cost of the stamps.
Give your answer in pounds (£).
- 6) A stationery supplier sells rulers for 23p each.
MathsWatch college buys 455 of these rulers.
Work out the total cost of these 455 rulers.
Give your answer in pounds (£).
- 7) A Maths book costs £1.99
Mr Smith buys a class set of 36 books.
Work out the total cost of the 36 books.
- 8) The cost of a calculator is £7.39
Work out the cost of 32 of these calculators.
- 9) Salvatore makes pizzas.
He receives an order for 34 pizzas.
Salvatore charges £2.55 for each pizza.
Work out the total amount he would charge for 34 pizzas.
- 10) A ream of tracing paper costs £3.23
Work out the cost of 45 reams of tracing paper.

- 1) Work out
- | | | |
|------------------|------------------|------------------|
| a) $325 \div 5$ | d) $377 \div 29$ | g) $75 \div 4$ |
| b) $448 \div 8$ | e) $27 \div 6$ | h) $135 \div 20$ |
| c) $221 \div 13$ | f) $123 \div 15$ | i) $381 \div 12$ |

- 2) A box can hold 19 books.
Work out how many boxes will be needed to hold 646 books.

- 3) The distance from Glasgow to Paris is 1290 km.
A flight from Glasgow to Paris lasts 3 hours.

Given that

$\text{Average speed} = \frac{\text{Distance}}{\text{Time}}$
--

Work out the average speed of the aeroplane in km/h.

- 4) Pencils cost 25p each.
Mr Smith spends £15 on pencils.
Work out the number of pencils he gets.
- 5) Yesterday, Gino was paid £19.61 for delivering pizzas.
He is paid 53p for each pizza he delivers.
Work out how many pizzas Gino delivered yesterday.
- 6) Emma sold 38 teddy bears for a total of £513
She sold each teddy bear for the same price.
Work out the price at which Emma sold each teddy bear.

- 7)
- | |
|--|
| Canal boat for hire
£1855.00
for 14 days |
|--|

Work out the cost per day of hiring the canal boat.

- 8) A teacher has £539 to spend on books.
Each book costs £26
How many books can the teacher buy?
- 9) John delivers large wooden crates with his van.
The weight of each crate is 68 kg.
The greatest weight the van can hold is 980 kg.
Work out the greatest number of crates that the van can hold.
- 10) Rulers costs 17p each.
MathsWatch High School has £120 to spend on rulers.
Work out the number of rulers bought.

1) Work out

a) 6×0.2

d) 0.2×0.8

b) 0.2×0.3

e) 0.03×0.9

c) 0.4×7

f) 1.5×0.2

2) A box contains 7 books, each weighing 2.5 kg.
Work out the total weight of the box.

3) John takes 13 boxes out of his van.
The weight of each box is 25.5 kg
Work out the total weight of the 13 boxes.

4) Work out

a) $9 \div 0.3$

d) $25 \div 0.5$

b) $6 \div 0.1$

e) $21 \div 0.3$

c) $12 \div 0.4$

f) $15 \div 0.2$

5) Work out

a) $3.6 \div 0.4$

d) $0.56 \div 0.08$

b) $0.8 \div 0.2$

e) $5.5 \div 0.05$

c) $2.4 \div 0.4$

f) $8.1 \div 0.09$

6) John takes boxes out of his van.
The total weight of the boxes is 4.9 kg
The weight of each box is 0.7 kg
Work out the number of boxes in John's van.

7) Mr Rogers bought a bag of elastic bands for £6
Each elastic band costs 12p.
Work out the number of elastic bands in the bag.

- 1) Round the following numbers to 1 decimal place
 - a) 13.681
 - b) 344.7234
 - c) 0.76133

- 2) Round the following numbers to 2 decimal places
 - a) 45.7241
 - b) 0.6851
 - c) 4623.33621

- 3) Round the following numbers to 1 significant figure
 - a) 4252
 - b) 26112
 - c) 7523987

- 4) Round the following numbers to 1 significant figure
 - a) 963
 - b) 9562
 - c) 991236

- 5) Round the following numbers to 1 significant figure
 - a) 0.005621
 - b) 0.07756
 - c) 0.0000523647

- 6) Round the following numbers to 2 significant figures
 - a) 752305
 - b) 147006
 - c) 296124

- 7) Round the following numbers to 2 significant figures
 - a) 0.00036264
 - b) 0.00045921
 - c) 0.0003654871

- 8) Round the following numbers to 3 significant figures
 - a) 923146
 - b) 0.0048912
 - c) 299622

- 9) Use a calculator to work out the following sums.
Give all answers to 3 significant figures.
 - a) 236×149
 - b) $17.3 \div 0.14$
 - c) $67 \div 3892$
 - d) 779×9984
 - e) $47.5 \div 0.0037$
 - f) $215 \times 3.2 \div 0.0018$

- 1) Which number is in the middle of
 - a) 3 and 9
 - b) 12 and 28
 - c) 11 and 22
 - d) 17 and 32
 - e) 72 and 108
 - f) 1 and 100
 - g) -6 and 2
 - h) -9 and -3
 - i) 3.2 and 3.8
 - j) 5.7 and 6.3
 - k) 58.3 and 73.5

- 2)
 - a) 7 is in the middle of 3 and which other number?
 - b) 16 is in the middle of 9 and which other number?
 - c) 2.4 is in the middle of 1.1 and which other number?

1) Write down the reciprocal of

a) 8

b) 3

c) 1

d) 12

2) Write down the reciprocal of

a) $\frac{1}{2}$

b) $\frac{1}{3}$

c) $\frac{1}{4}$

d) $\frac{1}{8}$

3) Write down the reciprocal of

a) 0.1

b) 0.5

c) 0.2

4) Why can't we have a reciprocal of 0?

Non-Calculator

- 1) 8 bananas cost £1.60
Work out the cost of 5 bananas.
 - 2) Emily bought 4 identical pairs of sock for £3.60
Work out the cost of 9 pairs of these socks.
 - 3) The price of a box of chocolates is £7.20
There are 36 chocolates in the box.
Work out the cost of one chocolate.
 - 4) Theresa bought 5 theatre tickets for £60
Work out the cost of 9 theatre tickets.
 - 5) Jenny buys 4 folders.
The total cost of these 4 folders is £6.40
Work out the total cost of 7 of these folders.
-

Calculator

- 6) The cost of 15 litres of petrol is £12
Work out the cost of 20 litres of petrol.
- 7) 3 maths books cost £7.47
Work out the cost of 5 of these.
- 8) Five 1 litre tins of paint cost a total of £48.75
Work out the cost of seven of these 1 litre tins of paint.
- 9) William earns £9.30 for $1\frac{1}{2}$ hours of work.
Work out how much he would earn for:
 - a) 30 minutes
 - b) 5 hours
- 10) It took 1 hour for Emyr to lay 150 bricks.
He always works at the same speed.
How long will it take Emyr to lay 720 bricks?
Give your answer in hours and minutes.

Distance Tables

- 1) The table shows the distances in kilometres between some cities in the USA.

San Francisco			
4827	New York		
4990	2132	Miami	
668	4541	4375	Los Angeles
3493	1352	2183	3366

Chicago

- a) Write down the distance between San Francisco and Miami.

One of the cities in the table is 4541 km from Los Angeles.

- b) Write down the name of this city.
- c) Write down the name of the city which is furthest from Chicago.

- 2) The table shows the distances in miles between four cities.

London			
155	Cardiff		
212	245	York	
413	400	193	Edinburgh

- a) Write down the distance between London and York.
- b) Write down the distance between Edinburgh and Cardiff.
- c) Which two cities are the furthest apart?

Tom travels from London to York.

He then travels from York to Edinburgh.

He finally travels back to London from Edinburgh.

- d) Work out the total distance travelled by Tom.

Peter and Jessica both drive to York.

Peter travels from London whilst Jessica travels from Cardiff.

- e) Who travels the furthest out of Peter and Jessica and by how much?

- 1) Change the following to the 24 hour clock
 - a) 4.30 pm
 - b) 5 am
 - c) 10.26 am
 - d) 7.15 pm
 - e) Quarter past midnight
 - f) Half past noon

- 2) Change the following to the 12 hour clock
 - a) 06 35
 - b) 14 30
 - c) 12 45
 - d) 19 15
 - e) 00 50
 - f) Half past midnight

- 3) What is the difference in hours and minutes between the following
 - a) 10.15 pm and 11.30 pm
 - b) 14 20 and 17 10
 - c) 11.50 pm and 3.20 am
 - d) 22 45 and 01 00

- 4) Here is part of a train timetable

Manchester	05 15	06 06	06 45	07 05	07 15	07 46
Stockport	05 26	06 16	06 55	07 15	07 25	07 55
Macclesfield	05 39	06 29	07 08		07 38	08 08
Stoke	05 54	06 45	07 24		07 54	08 24
Stafford	06 12		07 41		08 11	
Euston	08 09	08 26	09 06	09 11	09 50	10 08

- a) Tim catches the 06 06 train from Manchester.
At what time should he expect to arrive at Euston?

- b) Jenny arrives at the Stockport train station at 07 00
 - (i) How long should she expect to wait for a train to Stoke?
 - (ii) How long should her train journey take?

- c) Sarah needs to travel to Euston from Macclesfield.
She has to arrive at Euston before 09 30.
What is the departure time of the latest train she can catch to get there on time?

1) Write the following using indices:

eg. $3 \times 3 \times 3 \times 3 = 3^4$

a) $2 \times 2 \times 2 \times 2$

d) $12 \times 12 \times 12 \times 12 \times 12$

b) $4 \times 4 \times 4$

e) 3.6×3.6

c) $5 \times 5 \times 5 \times 5 \times 5 \times 5$

f) $5.2 \times 5.2 \times 5.2$

2) Write each of the following as a single power:

eg. $5^2 \times 5^4 = 5^6$

a) $6^2 \times 6^3$

d) $5^3 \times 5$

b) $7^4 \times 7^2$

e) $2^9 \times 2^3$

c) $9^3 \times 9^6$

f) $7.2^3 \times 7.2^2$

3) Write each of the following as a single power:

eg. $7^5 \div 7^2 = 7^3$

a) $9^5 \div 9^3$

d) $\frac{7^8}{7^3}$

b) $6^9 \div 6^5$

e) $\frac{3^6}{3}$

c) $11^7 \div 11^2$

f) $\frac{8^{15}}{8^4}$

4) Write each of the following as a single power:

eg. $\frac{7^3 \times 7^8}{7^6} = \frac{7^{11}}{7^6} = 7^5$

a) $\frac{4^7 \times 4^3}{4^6}$

b) $\frac{9^2 \times 9^6}{9^4}$

5) Match together cards with the same answer

5^7

$5^{10} \div 5^6$

$5^6 \times 5^2$

5^3

5^2

5^8

5×5

$\frac{5^2 \times 5^4}{5^3}$

$5^2 \times 5^5$

5^4

Line Graphs

1) The graph shows the number of ice creams sold each day during one week.

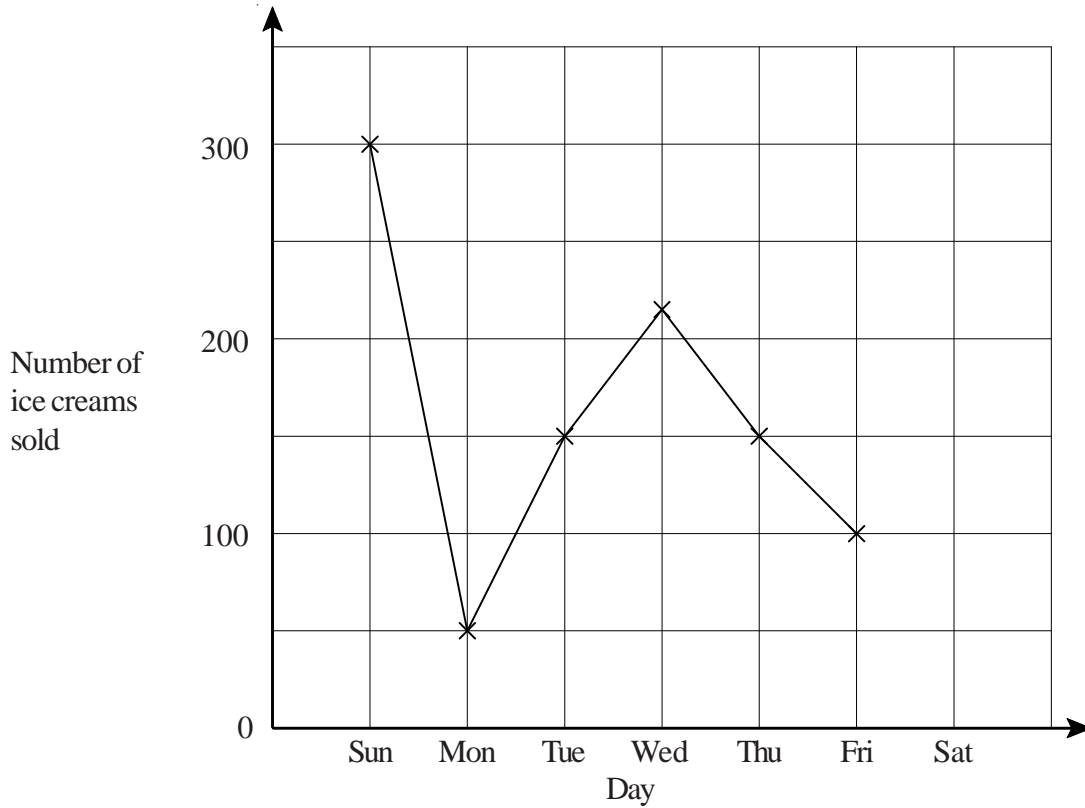

- a) How many more ice creams were sold on Sunday than on Friday?
- b) Explain what might have happened on Monday.
- c) On Saturday, 250 ice creams were sold.
Update the graph with this information.
- d) About how many ice creams were sold on Wednesday?

2) The average temperature, in degrees Centigrade, was recorded for each month.

The results are as follows:

January 5°C February 3°C March 8°C April 13°C May 15°C June 21°C

July 34°C August 29°C September 20°C October 12°C November 8°C December 6°C

Draw a line graph to show these results.

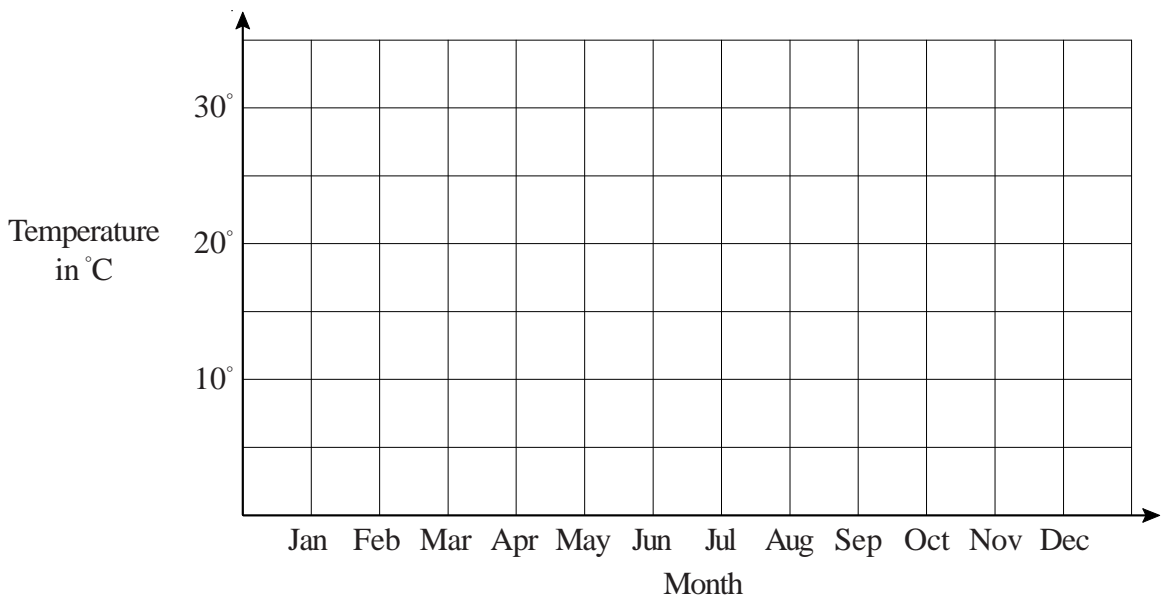

Coordinates

1. Write down the coordinates of the points *A* to *H*.

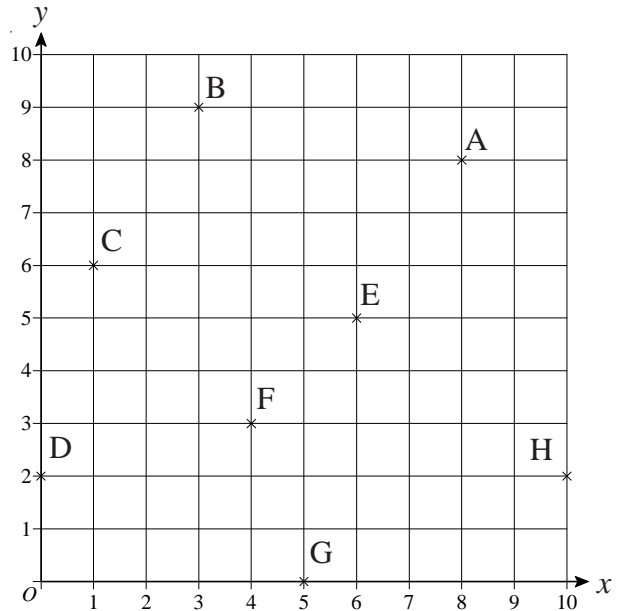

2. a) Write down the coordinates of: (i) *A* (ii) *B*

b) Write down the coordinates of the midpoint of the line *AB*.

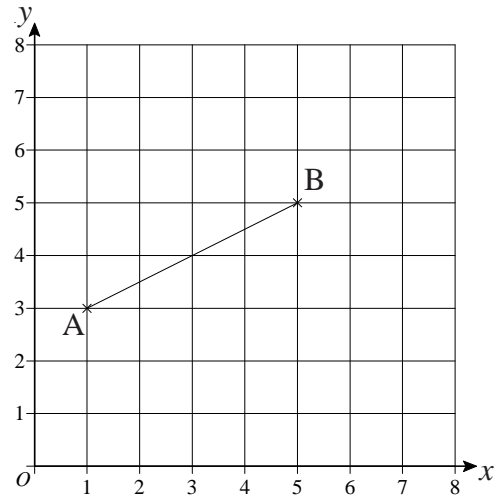

3. Using the pair of axes,

a) Plot the points *A*(2, 0), *B*(4, 0), *C*(5, 2) and *D*(3, 2).

b) Join the points in order, to form a shape and name the shape.

M is the midpoint of the line segment *AC*.

c) Find the coordinates of *M*.

4. Using the same pair of axes,

a) Plot the points *R*(-1, -2), *S*(1, 1) and *T*(-1, 2).

b) Join *R* to *S* and *S* to *T*.

RSTU is a kite.

c) Write the coordinates of point *U*.

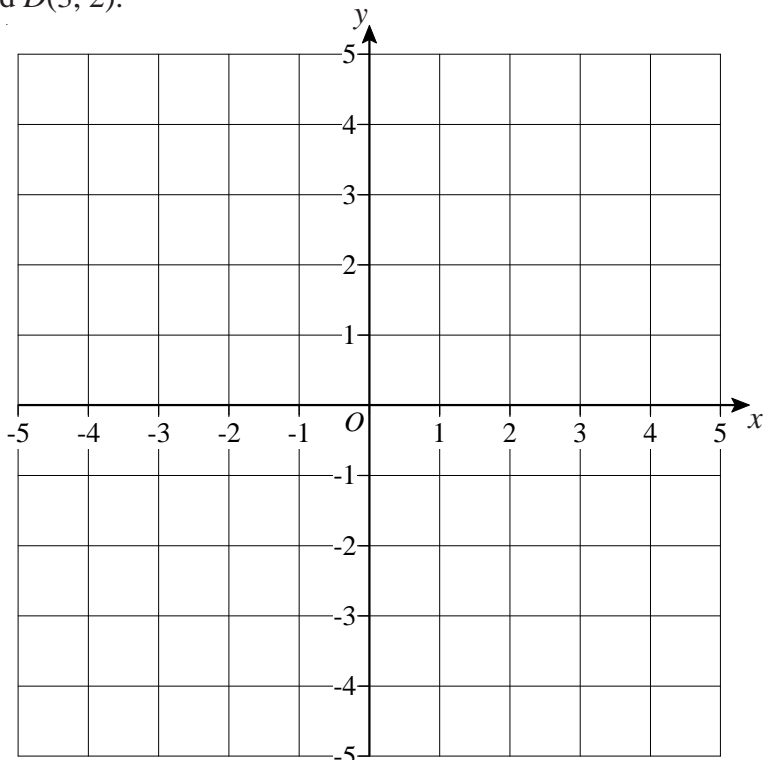

1) Here are some patterns made from matchsticks

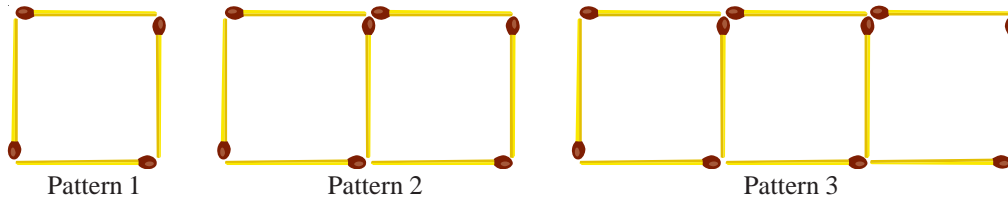

- a) Draw pattern 4.
- b) How many matchsticks are used in
 - (i) Pattern 5
 - (ii) Pattern 10
- c) Which pattern will have 46 matchsticks?

2) A pattern is made of rectangles and circles

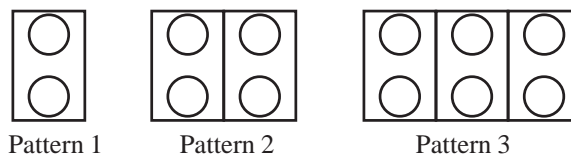

- a) Draw pattern 4.
- b) Complete the table below.

Pattern number	1	2	3	4	5	10
Number of rectangles	1	2				
Number of circles	2	4				
Total rectangles + circles	3	6				

- c) Which pattern will have 64 circles?
- d) Which pattern will have a total (rectangles + circles) of 90?

3) For each of the following sequences write down the next two terms.

- a) 5, 10, 15, 20...
- b) 9, 16, 23, 30...
- c) 27, 23, 19, 15...
- d) 12, 7, 2, -3...

4) Look at this number sequence: 4, 10, 16, 22...

The 50th term of the sequence is 298.

- a) Write down the 51st term.
- b) Will 643 be a term in this sequence?
Explain your answer.

- 1) Here is a table for the rule $\times 3$ then -1

$\times 3$ then -1	
Input	Output
1	2
2	
3	
5	
	20
	35

Complete the table.

- 2) Here is the table for the rule $+5$ then $\div 2$

$+5$ then $\div 2$	
Input	Output
1	3
2	3.5
3	
4	
	7
	10

Complete the table.

- 3) Here is a table for the rule $\times 4$ then -3 then $\times 2$

$\times 4$ then -3 then $\times 2$	
Input	Output
1	2
2	10
3	
5	
7	
	74
	82

Complete the table.

- 1) a) One of these angles is an acute angle.
Which one?

- b) Write the names of the other three angles next to them.

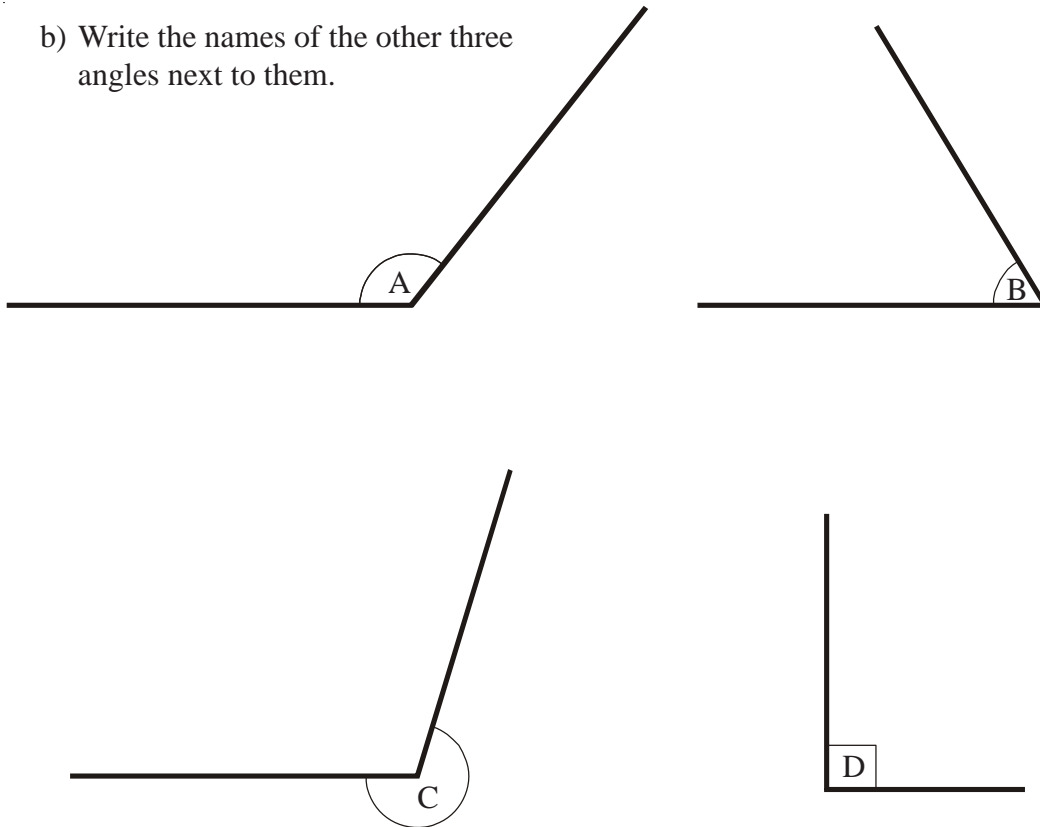

- 2) a) Sketch a triangle which has three internal (inside) acute angles.
b) Sketch a right-angled triangle.
c) Sketch a triangle with one internal obtuse angle.
- 3) Debbie says she is going to draw a triangle with two internal obtuse angles.
Harry says that this is impossible.
Is Harry correct? Explain why.
- 4) Draw a quadrilateral with
a) Two internal acute angles, one reflex angle and one obtuse angle.
b) Three internal acute angles and one reflex angle.

Congruent and Similar Shapes

	Congruent to	Similar to
A		
B		
C		
D		
E		
F		
G		
H		
I		
J		

Fill in the table on the left.

You are allowed to use tracing paper to help get the correct answers.

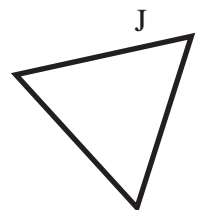
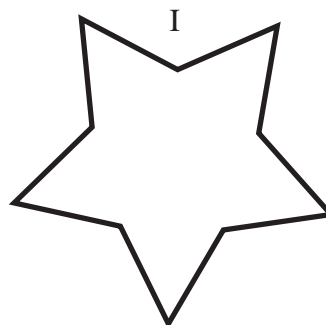
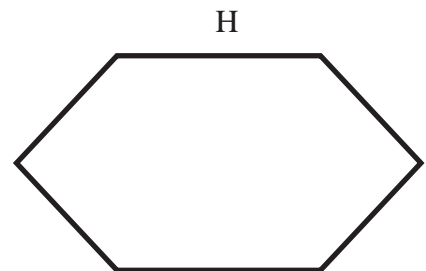
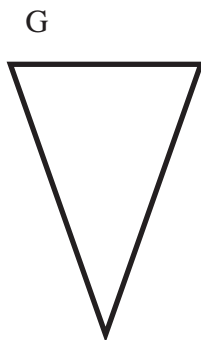
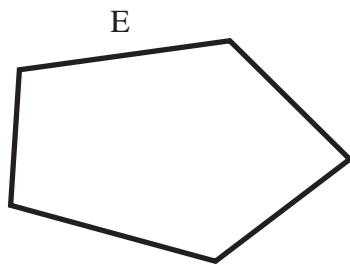
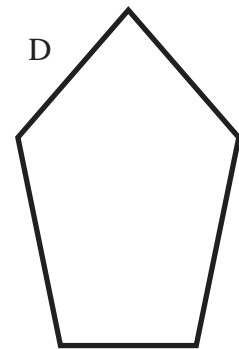
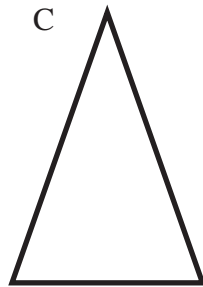
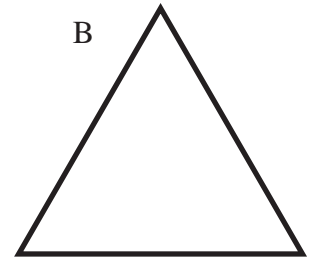
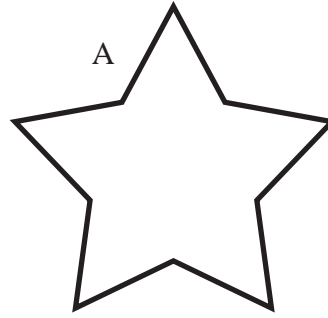

Perimeter and Areas

- 1) Find the perimeter of the following rectangle and pentagon:

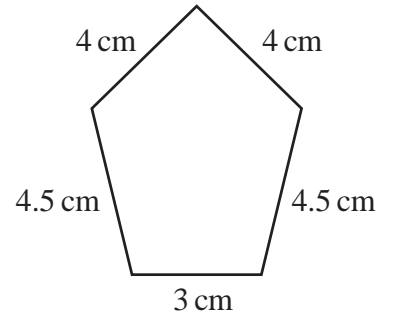
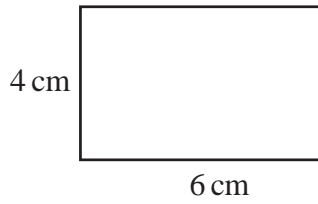

- 2) A rectangle has a perimeter of 40 cm. The length of the longest side is 12 cm. Sketch the rectangle, and find the length of the shorter side.

- 3) Find the area of the following rectangles:

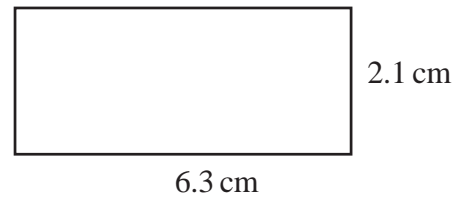
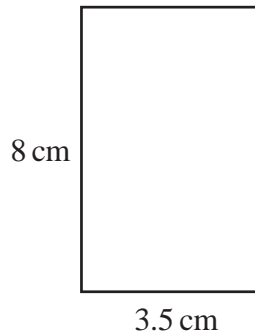
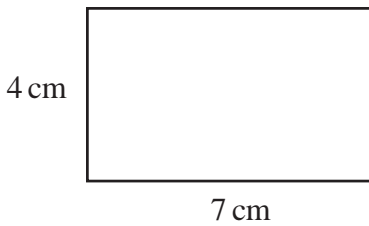

- 4) A rectangle has an area of 40cm^2 and a length of 8 cm. Sketch the rectangle and find the width.

- 5) Why can't we find the area of this parallelogram?

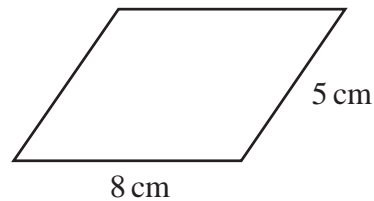

- 6) What is the area of the parallelogram, below?

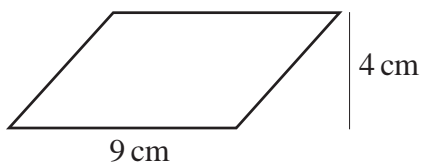

- 7) Find the area of the following triangles:

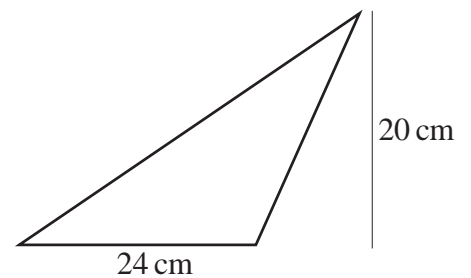
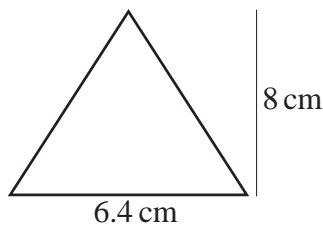
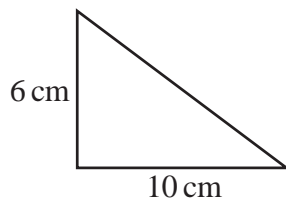

- 8) The area of a triangle is 60cm^2 . The base of the triangle is 12 cm long. Sketch a triangle with this area and base and work out the height of the triangle.

1) Find the volume of this cuboid.

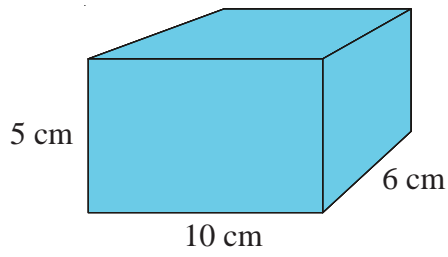

2) Find the volume of this cuboid.

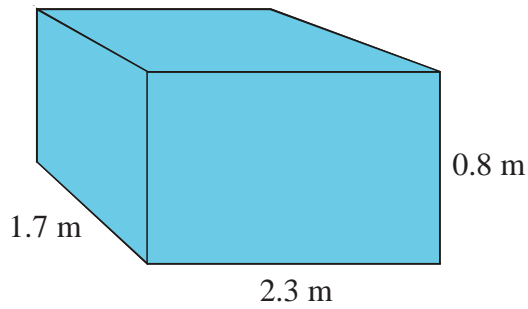

3) The volume of this cuboid is 480 cm^3 .
Find the length of the side marked x .

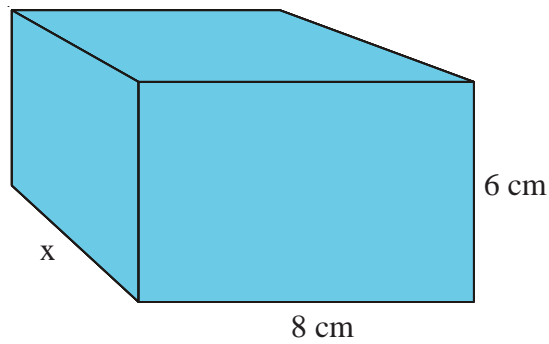

4) Boxes A and B are both cuboids.
How many of box B could be packed into box A?

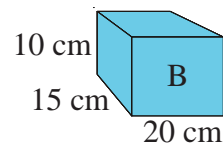
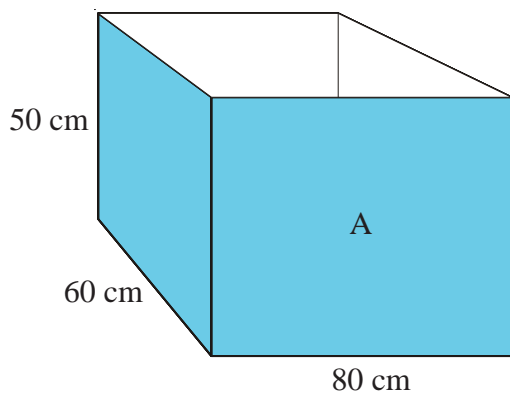

Converting Metric Measures

- 1) Complete this table by writing down a sensible unit for each measurement.
Four have been done for you.

	Metric	Imperial
The distance between London and Manchester		miles
The length of a pen	cm	
The weight of your Maths Teacher		pounds
The amount of petrol in a car		gallons
The length of an ant		

- 2) Change the following measurements:

a) 4 cm to mm

d) 10 cm to mm

g) 1 km to m

b) 7 m to cm

e) 25 m to mm

h) 1 km to cm

c) 5 m to mm

f) 34 m to cm

i) 23 km to m

- 3) Change the following measurements:

a) 300 cm to m

d) 6 cm to m

g) 4386 cm to m

b) 4 mm to cm

e) 412 cm to m

h) 549 mm to cm

c) 7425 mm to m

f) 1500 m to km

i) 0.3 km to m

- 4) Change the following measurements:

a) 5 m² to cm²

d) 8.2 m² to cm²

g) 5.1 m³ to cm³

b) 8 cm² to mm²

e) 7320 mm² to cm²

h) 53478 mm³ to cm³

c) 250 cm² to m²

f) 8 m³ to cm³

i) 183000 cm³ to m³

Triangles, Quadrilaterals, Polygons

For each of the shapes A to N, below:

- Name the shape.
- Mark on the shape, or write in words, the features that make it special.
- Shape A is a **square** because it has four equal sides and four right angles.

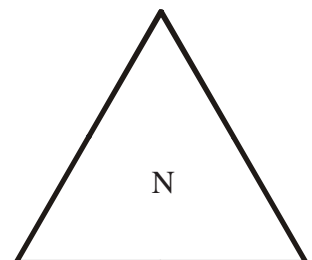
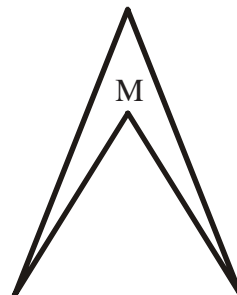
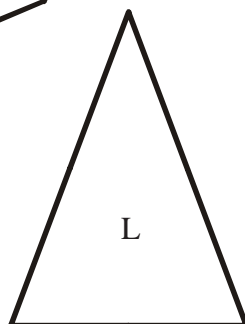
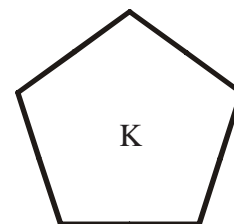
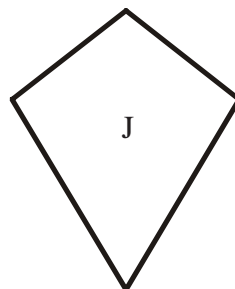
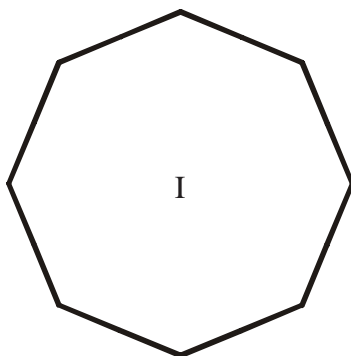
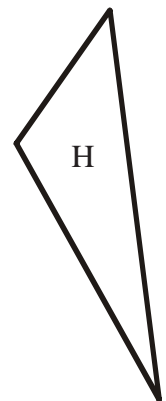
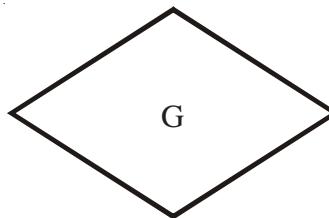
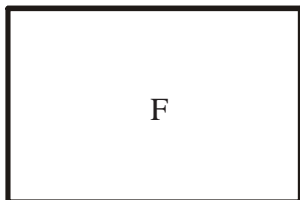
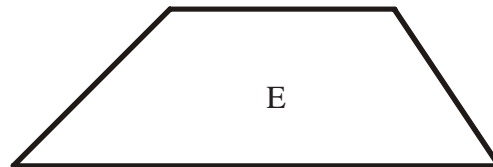
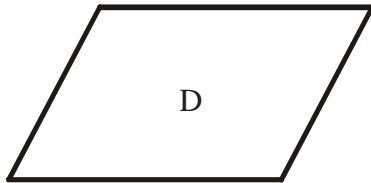
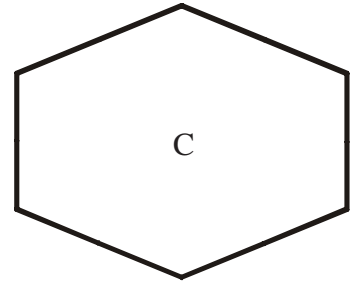
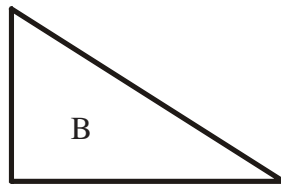
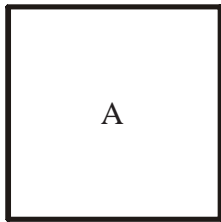

1) Draw a sketch of each of the following solids:

- a) A cube.
- b) A cylinder.

2) Write down the mathematical name of each of these 3-D shapes.

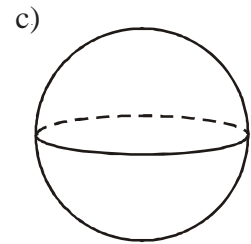
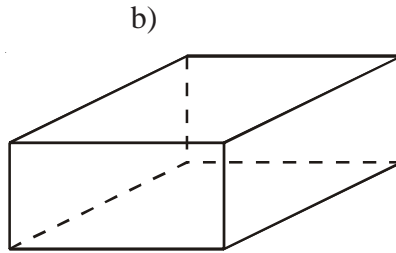
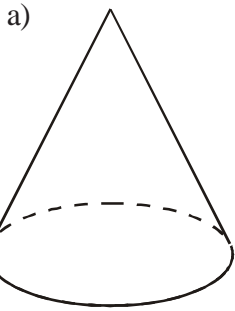

3) Look at this solid.

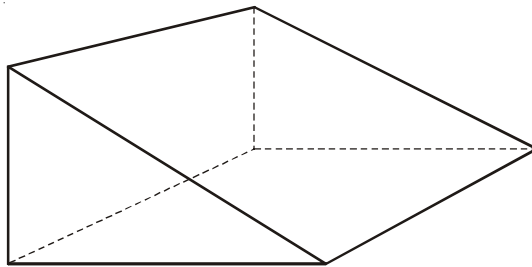

- a) What is its name?
- b) How many vertices does it have?
- c) How many edges are there?
- d) How many faces does it have?

4) This is a picture of a pentagonal prism.

- a) How many faces does it have?
- b) How many edges does it have?
- c) How many vertices does it have?

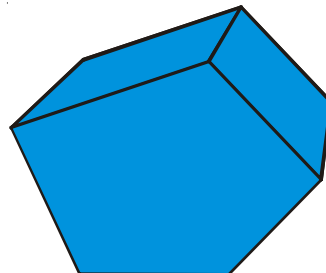

- 1) On the grid below, show how the shaded shape will tessellate.
You should draw at least six shapes.

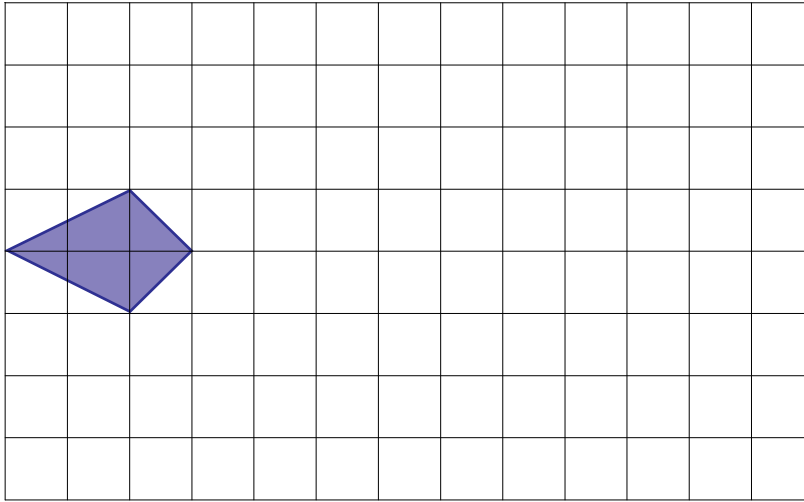

- 2) On the grid below, show how the shaded shape will tessellate.
You should draw at least six shapes.

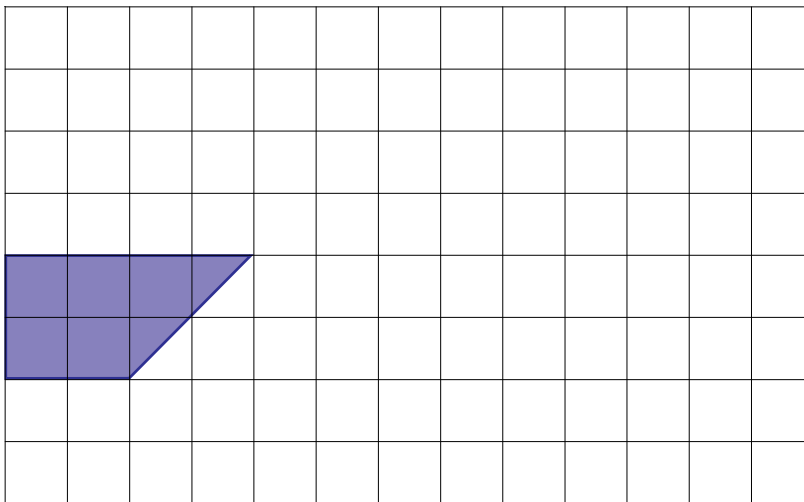

- 3) On the grid below, show how the shaded shape will tessellate.
You should draw at least six shapes.

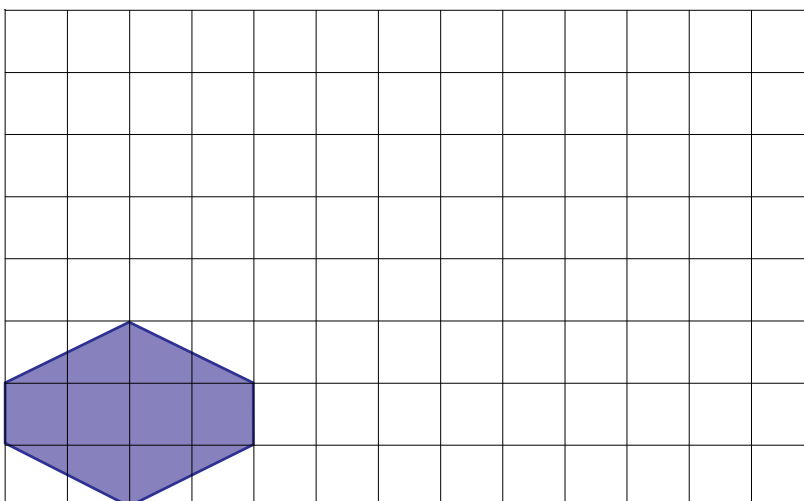

Isometric Drawing

- 1) Copy the shape below, onto the isometric grid.

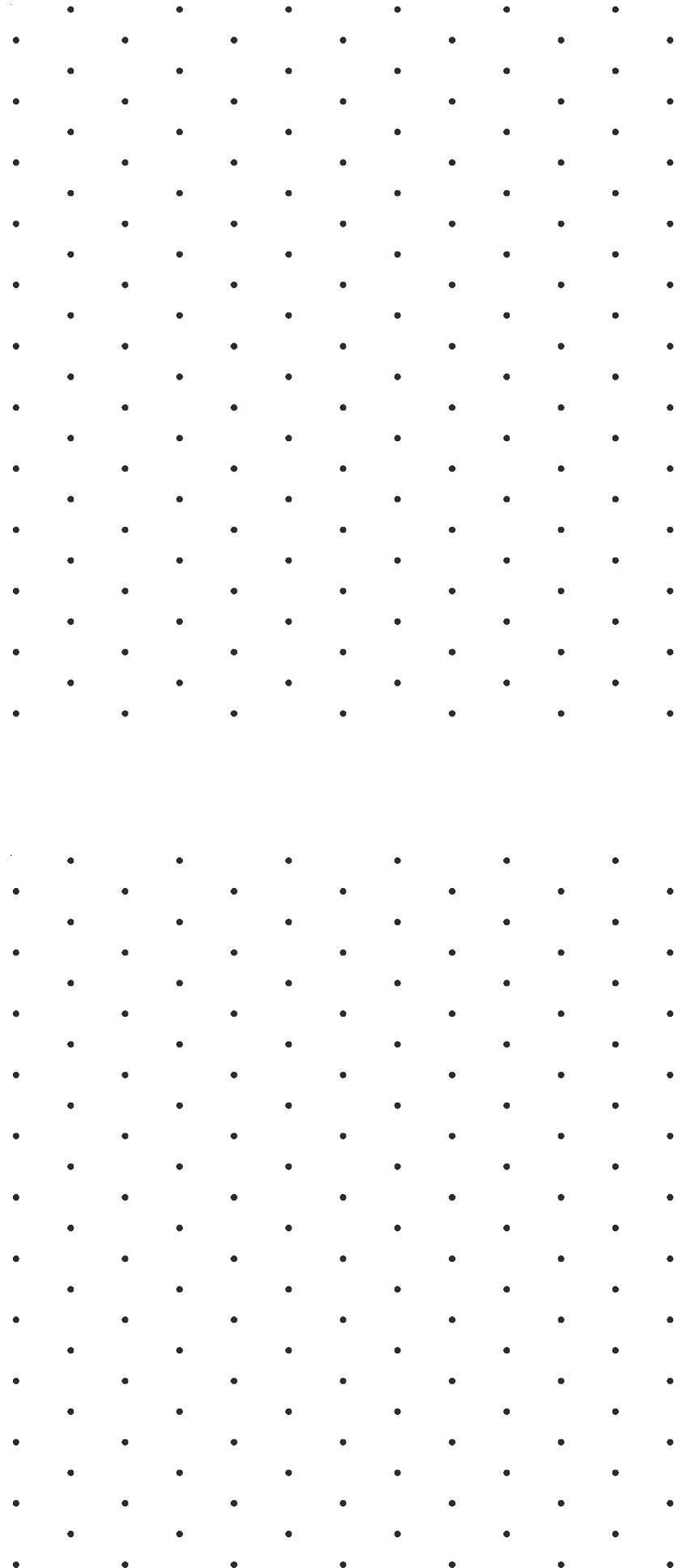
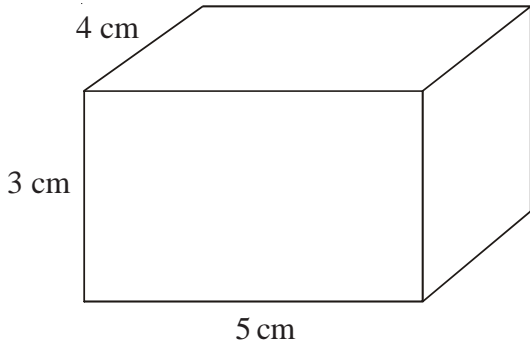

- 2) The shape below, is made out of 2 cm by 2 cm by 2 cm cubes.
Copy the shape onto the isometric grid.

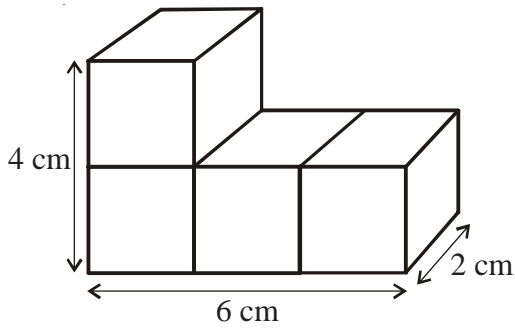

The Probability Scale

- 1) a) On the probability scale below, mark with a cross (×) the probability that it will snow in Birmingham in July.

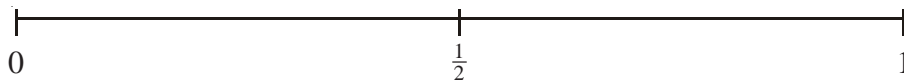

- b) On the probability scale below, mark with a cross (×) the probability that it will rain in Wales next year.

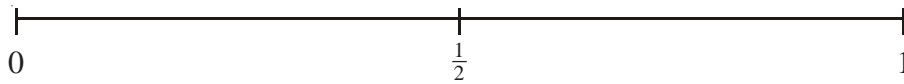

- c) On the probability scale below, mark with a cross (×) the probability that you will get a tail when you flip a fair coin.

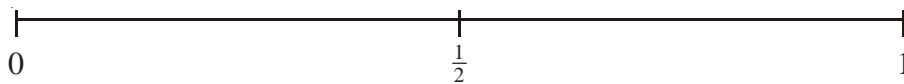

- d) On the probability scale below, mark with a cross (×) the probability that you will get a number bigger than 4 when you roll an ordinary dice.

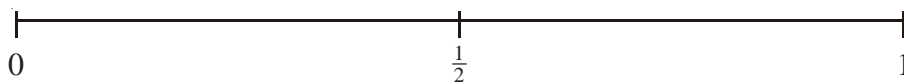

- 2) 4 jelly babies are in a bag.
2 are red, 1 is green and 1 is black.

Without looking in the bag, a jelly baby is taken out.

- a) On the probability scale below, mark with a cross (×) the probability that the jelly baby taken from the bag is green.

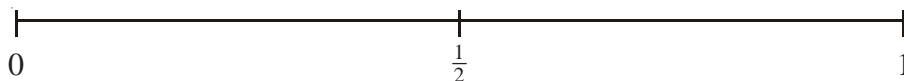

- b) On the probability scale below, mark with a cross (×) the probability that the jelly baby taken from the bag is green or black.

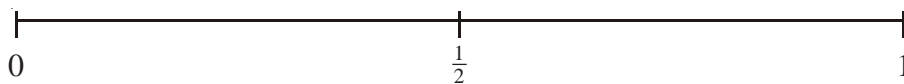

- c) On the probability scale below, mark with a cross (×) the probability that the jelly baby taken from the bag is red or black.

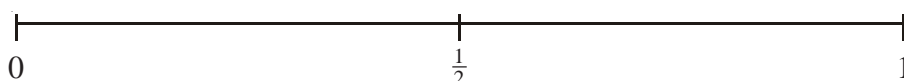

- 1) Kaya made a list of his homework marks.

3 2 3 4 1 4 5 5 2 4

- a) Write down the mode of Kaya's marks.
b) Work out his mean homework mark.

- 2) Lydia rolled an 8-sided dice ten times.

Here are her scores.

5 1 2 5 3 8 6 6 3 2

- a) Work out Lydia's median score.
b) Work out the mean of her scores.
c) Work out the range of her scores.

- 3) 20 students scored goals for the school football team.

The table gives information about the number of goals they scored.

Goals scored	Number of students	
1	8	
2	3	
3	6	
4	3	

- a) Write down the modal number of goals scored.
b) Work out the range of the number of goals scored.
c) Work out the mean number of goals scored.

- 4) Laura spun a 4-sided spinner 100 times.

The sides of the spinner are labelled 1, 2, 3 and 4.



Her results are shown in the table.

Score	Frequency
1	24
2	30
3	21
4	25

Work out the mean score.

Pictograms

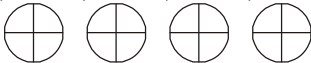
- 1) The pictogram shows the number of watches sold by a shop in January, February and March.

January	
February	
March	
April	
May	

Key  represents 4 watches.



- a) How many watches were sold in January?
 b) Work out how many **more** watches were sold in March than in February?

19 watches were sold in April.

14 watches were sold in May.

- c) Use this information to complete the pictogram.

- 2) The pictogram shows the number of DVDs borrowed from a shop on Monday and Tuesday.

Monday	
Tuesday	
Wednesday	
Thursday	

Key  represents 10 DVDs.

- a) How many DVDs were borrowed on
 (i) Monday,
 (ii) Tuesday

On Wednesday, 50 DVDs were borrowed.

On Thursday, 15 DVDs were borrowed.

- b) Show this information in the pictogram.

Conversion Graphs

1) Use the graph to convert:

- a) 11 gallons to litres
- b) 40 litres to gallons
- c) 15 gallons to litres
- d) 25 litres to gallons

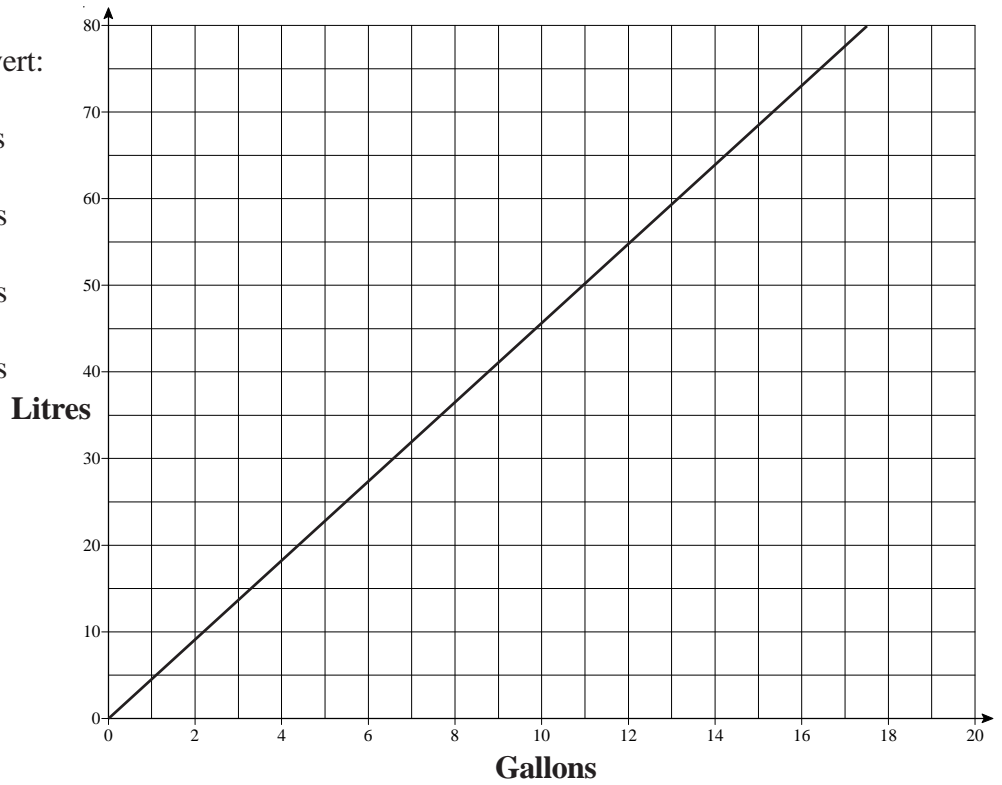

2) The conversion graph below converts between kilometres and miles.

- a) Bob travels 50 miles.
What is this distance in kilometres?
- b) Terry travels 100 kilometres.
What is this distance in miles?
- c) The distance between the surgery and the hospital is 25 kilometres.
What is this distance in miles?
- d) Bill completes a 10 mile run.
How far is this in kilometres?

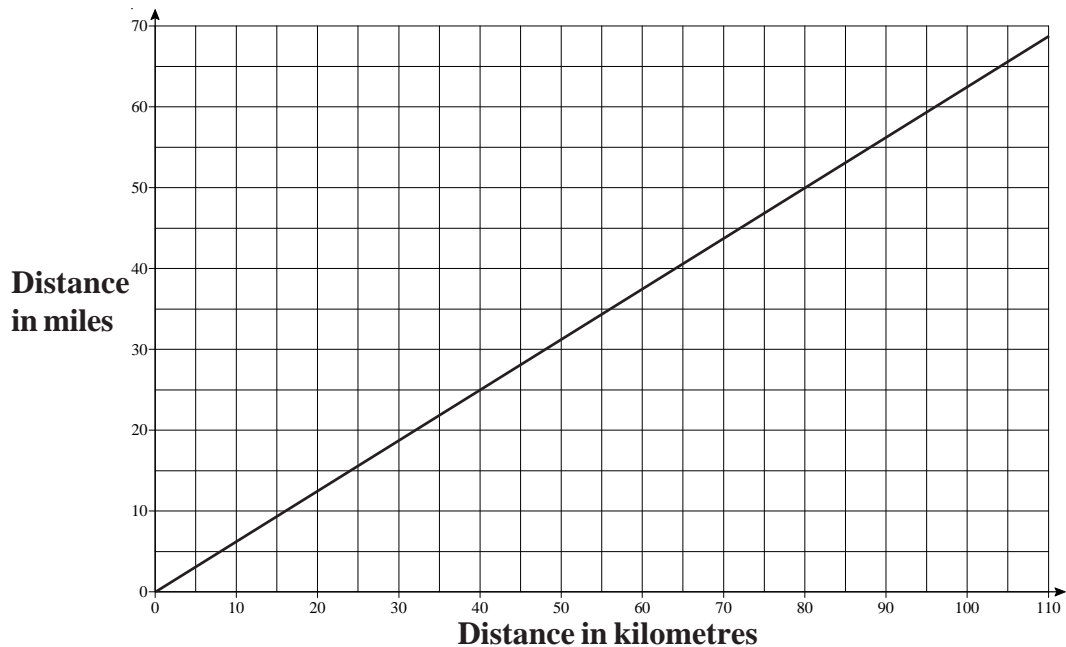

1) Write the factors of

a) 6

b) 16

c) 18

d) 30

2) In a pupil's book the factors of 12 are listed as

1 2 3 4 5 12

The above list contains a mistake.

Cross it out from the list and replace it with the correct number.

3) The factors of 30 and 40 are listed

30: 1, 2, 3, 5, 6, 10, 15, 30

40: 1, 2, 4, 5, 8, 10, 20, 40

Write the common factors of 30 and 40 (the numbers that are factors of 30 and 40).

4) Write the first four multiples of

a) 3

b) 5

c) 10

d) 15

5) In a pupil's book the first 7 multiples of 8 are listed as

8 16 22 32 40 48 54

The above list contains 2 mistakes.

Cross them out and replace them with the correct numbers.

6) The first five multiples of 4 and 10 are listed

4: 4, 8, 12, 16, 20

10: 10, 20, 30, 40, 50

From the two lists above, write the common multiple of 4 and 10.

7) List the first five prime numbers

8) Using just this list of numbers:

11 18 1 4 21 24 9 3 12 2 19

find the following:

a) The prime numbers

b) The factors of 18

c) The multiples of 3

1. Evaluate

a) 7^2

b) 2^4

c) 5^2

d) 3^3

e) 1^6

2. Work out the square of

a) 1

b) 2

c) 4

d) 6

e) 11

3. Work out

a) 3^2

b) 9^2

c) 10^2

d) 12^2

e) 100^2

4. Work out the cube of

a) 1

b) 3

c) 5

d) 6

e) 100

5. Work out

a) 2^3

b) 4^3

c) 10^3

6. Work out the square root of

a) 1

b) 9

c) 81

7. Work out

a) $\sqrt{25}$

b) $\sqrt{49}$

c) $\sqrt{121}$

8. Work out the cube root of

a) 27

b) 1

c) 125

9. From the following numbers

4 27 8 64 16 19 100 360 45 3

Find

a) The square numbers

b) The cube numbers

c) The square root of 64

d) The cube root of 27

10. Match together cards with the same answer

9^2

$\sqrt{9}$

81

5^3

2^5

125

32

3

Equivalent Fractions, Simplifying and Ordering Fractions

1) Write down three equivalent fractions for each of these

a) $\frac{3}{4}$

b) $\frac{2}{5}$

c) $\frac{7}{8}$

2) Match together equivalent fractions

$\frac{10}{15}$

$\frac{3}{5}$

$\frac{18}{21}$

$\frac{21}{35}$

$\frac{2}{3}$

$\frac{6}{7}$

$\frac{30}{50}$

3) Find the missing values in these equivalent fractions

a) $\frac{1}{4} = \frac{\square}{8} = \frac{4}{\square} = \frac{\square}{40}$

c) $\frac{4}{5} = \frac{12}{\square} = \frac{20}{\square} = \frac{\square}{35} = \frac{\square}{60}$

b) $\frac{6}{9} = \frac{\square}{3} = \frac{\square}{90} = \frac{48}{\square} = \frac{66}{\square}$

d) $\frac{4}{10} = \frac{24}{\square} = \frac{\square}{5} = \frac{48}{\square} = \frac{\square}{200}$

4) Write these fractions in their simplest form

a) $\frac{24}{48}$

b) $\frac{8}{20}$

c) $\frac{45}{63}$

d) $\frac{39}{45}$

e) $\frac{72}{104}$

5) Write these fractions in order of size (smallest first)

a) $\frac{3}{8}, \frac{9}{16}, \frac{1}{4}, \frac{5}{16}$

c) $\frac{5}{8}, \frac{4}{6}, \frac{3}{24}, \frac{7}{12}$

b) $\frac{2}{3}, \frac{7}{12}, \frac{3}{4}, \frac{5}{6}$

d) $\frac{6}{10}, \frac{4}{5}, \frac{5}{12}, \frac{16}{30}$

6) Ben spent his pocket money this way:

$\frac{7}{20}$ on magazines;

$\frac{4}{10}$ on chocolates;

$\frac{1}{4}$ on games.

Order the items Ben bought by value (largest first).

Show all working

- 1) Which of the following offer better value for money?

Working must be shown

*Without a calculator,
please, for question 1.*

a) 200ml of toothpaste for 50p or 400ml of toothpaste for 90p

b) 600g of bananas for 70p or 200g of bananas for 22p

c) 2 litres of paint for £1.60 or 5 litres of paint for £3.50

d) 60 teabags for £1.62 or 40 teabags for £0.96

- 2) Which of these is the best buy?

Working must be shown

20 exercise books
for £4.00

35 exercise books
for £7.80

- 3) Hamza needs to buy 2 litres of paint.

At the shop he gets two choices:

500ml for £2.55 or 1 litre for £4.79.

*Without a calculator,
please, for question 3.*

a) Work out which of these would be the best buy for Hamza.

b) How much does he save if he buys the 'best buy' rather than the 'worst buy'.

You must show all your working.

- 4) Honey pots are sold in two sizes.

A small pot costs 45p and weighs 450g.

A large pot costs 80p and weighs 850g.

Which pot of honey is better value for money?

You must show all your working.

Find a Percentage with a Calculator

- 1) Work out
- a) 21% of 340
b) 9% of 2700
c) 17.5% of 420
- d) 3.5% of 78.6
e) 80.5% of 3200
f) 117.5% of 35
- 2) Work out the total cost (including VAT) of the following items.

Trainers
£45.50
plus 17.5% VAT

Tennis racquet
£28.99
plus 17.5% VAT

Football boots
£57
plus 17.5% VAT

- 3) 850 people attended a festival.
16% of the people were children.
Work out the number of children at the festival.
-

Find a Percentage Without a Calculator

- 1) Work out (i) 10% and (ii) 5% and (iii) 15% of:
- a) 200 b) 30 c) 450 d) 54
- 2) Work out
- a) 30% of 280
b) 80% of 3500
c) 15% of 540
- d) 17.5% of 300
e) 55% of 700
f) 17.5% of 180
- 3) Work out the total cost (including VAT) of the following items.

Video recorder
£200 + 17.5% VAT

Tape player
£60 + 17.5% VAT

Laptop
£1200 + 17.5% VAT

- 4) There are 1300 students at MathsWatch College.
45% of these students are boys.
Work out the number of boys.

Change to a Percentage With a Calculator

- 1) In a class of 37 pupils, 22 are boys.
 - a) What percentage of the class are boys?
 - b) What percentage of the class are girls?
- 2) Sarah sat a mock examination and gained the following marks:

Subject	Mark
English	$\frac{82}{94}$
Maths	$\frac{79}{123}$
Science	$\frac{38}{46}$

- a) Write each of Sarah's marks as a percentage.
 - b) Which is Sarah's best subject in terms of percentage score?
- 3) A brand new car costs £16 500.
A discount of £2 227.50 is negotiated with the dealer.
What is the percentage discount?

Change to a Percentage Without a Calculator

- 1) Write the following as percentages:
 - a) 13 out of 50
 - b) 6 out of 20
 - c) 17 out of 25
 - d) 34 out of 40
 - e) 12 out of 80
 - f) 27 out of 60
- 2) In a football tournament, Team A won 16 of the 20 games they played, whilst team B won 19 of their 25 games.
What percentage of their games did they each win?
- 3) 60 participants were invited to a conference.
36 of the participants were females.
 - a) Work out the percentage of female participants.
 - b) What is the percentage of male participants?
- 4) A company has 800 employees.
440 of these 800 employees are males.
176 of these 800 employees are under 25 years old.
 - a) What percentages of males are employed in this company?
 - b) What percentage of employees are under 25?

1. Work out these amounts.

a) $\frac{3}{4}$ of £20

b) $\frac{2}{3}$ of 60 kg

c) $\frac{3}{8} \times 24$

d) $150 \times \frac{2}{3}$

e) $\frac{2}{9}$ of 180 cm

f) $49 \times \frac{4}{7}$

g) $60 \times \frac{1}{4}$

h) $\frac{5}{8}$ of £48

i) $4000 \times \frac{7}{8}$

2. There are 600 apples on a tree and there are maggots in $\frac{3}{5}$ of them.

How many apples have maggots in them?

3. Liz and Lee are travelling in a car from Glasgow to Poole (770 km).

At midday they had already travelled $\frac{5}{7}$ of the total distance.

What distance, in km, had they travelled by midday?

4. A digital camera that cost £49 was sold on eBay for $\frac{3}{7}$ of the original price.

What was the selling price?

5. Yesterday Thomas travelled a total of 175 miles.

He travelled $\frac{2}{5}$ of this distance in the morning.

How many miles did he travel during the rest of the day?

6. Debra received her £15 pocket money on Saturday.

She spent $\frac{1}{3}$ of her pocket money on magazines.

She spent $\frac{2}{5}$ of her pocket money on a necklace.

How much of the £15 did she have left?

1. Work out the following giving your answer as a fraction in its simplest form

a) $\frac{3}{5} + \frac{1}{5}$ b) $\frac{3}{7} + \frac{2}{7}$ c) $\frac{5}{8} - \frac{3}{8}$ d) $\frac{7}{13} - \frac{4}{13}$

2. Work out the following giving your answer as a fraction in its simplest form

a) $\frac{3}{5} + \frac{2}{10}$ b) $\frac{1}{3} + \frac{2}{9}$ c) $\frac{13}{20} - \frac{3}{5}$ d) $\frac{9}{12} - \frac{1}{3}$

3. Change the following to mixed numbers

a) $\frac{8}{5}$ b) $\frac{14}{3}$ c) $\frac{35}{6}$ d) $\frac{17}{5}$

4. Change the following to top heavy (or improper) fractions

a) $1\frac{2}{5}$ b) $3\frac{1}{4}$ c) $6\frac{1}{5}$ d) $2\frac{5}{9}$

5. Work out the following giving your answer as a fraction in its simplest form

a) $1\frac{2}{5} + 6\frac{1}{5}$ b) $2\frac{3}{4} + 1\frac{1}{5}$ c) $4\frac{1}{6} - 3\frac{1}{3}$ d) $7\frac{4}{9} - 2\frac{5}{9}$

6. Work out the following giving your answer as a fraction in its simplest form

a) $\frac{3}{4} - \frac{1}{5}$ b) $\frac{5}{11} + \frac{3}{11}$ c) $5\frac{1}{2} - \frac{2}{3}$ d) $\frac{7}{12} + \frac{3}{4}$

e) $2\frac{4}{5} + 9\frac{2}{5}$ f) $\frac{2}{7} + \frac{1}{2}$ g) $9\frac{1}{4} - 5\frac{2}{5}$ h) $\frac{12}{15} - \frac{7}{15}$

7. Ted received his pocket money on Friday.

He spent $\frac{3}{5}$ of his pocket money on games.

He spent $\frac{1}{10}$ of his pocket money on magazines.

What fraction of his pocket money did he have left?

8. Maisie buys a bag of flour.

She uses $\frac{1}{4}$ to bake a cake and $\frac{2}{5}$ to make a loaf.

a) What fraction of the bag of flour was used?

b) What fraction of the bag of flour is left?

9. Work out the total length of this shape.
Give your answer as a mixed number.

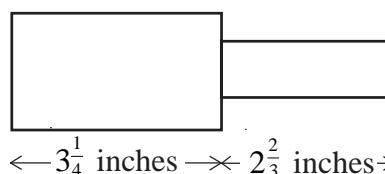

Diagram **NOT**
accurately drawn

Work out the following giving your answer as a fraction in its simplest form.

1) $\frac{4}{5} \times \frac{1}{3}$

11) $\frac{1}{3} \div \frac{5}{6}$

2) $\frac{3}{4} \times \frac{2}{3}$

12) $\frac{2}{7} \div \frac{10}{21}$

3) $\frac{3}{10} \times \frac{4}{9}$

13) $\frac{4}{5} \div 8$

4) $\frac{3}{7} \times \frac{5}{6}$

14) $\frac{4}{11} \div \frac{4}{11}$

5) $\frac{6}{25} \times \frac{15}{18}$

15) $\frac{4}{5} \div \frac{8}{9}$

6) $\frac{4}{15} \times \frac{3}{16}$

16) $\frac{5}{8} \div \frac{10}{19}$

7) $2\frac{2}{3} \times 3\frac{3}{4}$

17) $1\frac{2}{3} \div 2\frac{1}{2}$

8) $1\frac{2}{3} \times 3\frac{3}{10}$

18) $3\frac{1}{5} \div 2\frac{2}{3}$

9) $4\frac{2}{3} \times \frac{5}{7}$

19) $25 \div 2\frac{1}{7}$

10) $\frac{3}{5} \times 12\frac{1}{2}$

20) $\frac{2}{3} \div 2\frac{2}{9}$

Write the following fractions as decimals

1) $\frac{3}{10}$

2) $\frac{7}{10}$

3) $\frac{9}{100}$

4) $\frac{1}{2}$

5) $\frac{3}{4}$

6) $\frac{2}{5}$

7) $\frac{7}{20}$

8) $\frac{1}{3}$

9) $\frac{1}{8}$

10) $\frac{5}{8}$

Work out

1) $6 \times 5 + 2$

2) $2 + 6 \times 5$

3) $35 - 4 \times 3$

4) $48 \div (14 - 2)$

5) $27 \div (3 + 6)$

6) $27 \div 3 + 6$

7) $(9 + 2) \times 2 + 5$

8) $4 \times (1 + 4) - 6$

9) $6 \times 4 - 3 \times 5$

10) $\frac{9+3}{4+2}$

11) $\frac{23+9}{7-3}$

12) $\frac{7-2^2}{4^2-15}$

13) $\frac{5^2+3}{2 \times 7}$

14) $\frac{5 \times 6 - 4}{13}$

15) $\frac{8 \times 2 - 4}{3 + 1^2}$

16) $\frac{12 - 3 \times 2}{14 \div 7}$

17) $\frac{20 - 3^2}{10 - (5 + 4)}$

18) $\frac{3 + 9 \times 8}{1 + 6 \times 4}$

1. Work out

a) 7×4.3

b) 5×3.16

c) 2.3×1.2

d) 7.2×42.5

e) 12.5×0.59

f) 0.652×0.37

g) 5.62×9

h) 26.7×4.9

i) 1.56×0.059

2. David buys 5 books for £8.75 each.

How much does he pay?

3. A DVD costs £12.25.

Work out the cost of 9 of these DVDs.

4. John takes 27 boxes out of his van.

The weight of each box is 41.7 kg.

Work out the total weight of the 27 boxes.

5. Nina bought 43 teddy bears at £9.35 each.

Work out the total amount she paid.

6. Elliott goes shopping.

He buys

0.5 kg of pears at £0.84 per kg.

2.5 kg of grapes at £1.89 per kg.

6 kg of potatoes at £0.25 per kg.

How much does he pay?

7. Brian hires a car for 3 days.

Tariffs are:

£44.80 for the first day and

£37.50 for each extra day.

How much does he pay?

1. Write the following ratios in their simplest form

a) $6 : 9$

b) $10 : 5$

c) $7 : 21$

d) $4 : 24$

e) $12 : 40$

f) $18 : 27$

g) $4 : 2 : 8$

h) $18 : 63 : 9$

2. Complete the missing value in these equivalent ratios

a) $3 : 5 = 12 : \square$

b) $4 : 9 = \square : 27$

c) $\square : 7 = 16 : 14$

d) $2 : 3 = 3 : \square$

3. Match together cards with equivalent ratios:

$3 : 4$

$10 : 5$

$50 : 100$

$2 : 1$

$5 : 2$

$15 : 20$

$15 : 6$

$1 : 2$

4. The ratio of girls to boys in a class is $4 : 5$.

a) What fraction of the class are girls?

b) What fraction of the class are boys?

5. A model of a plane is made using a scale of $1 : 5$.

a) If the real length of the plane is 20m, what is the length of the model in metres?

b) If the wings of the model are 100cm long, what is the real length of the wings in metres?

6. Share out £250 in the following ratios:

a) $1 : 4$

b) $2 : 3$

c) $7 : 3$

d) $9 : 12 : 4$

7. Share out £80 between Tom and Jerry in the ratio $3 : 2$.

8. A box of chocolates has 3 milk chocolates for every 2 white chocolates.

There are 60 chocolates in the box.

Work out how many white chocolates are in the box.

9. In a bracelet, the ratio of silver beads to gold beads is $5 : 2$.

The bracelet has 25 silver beads.

How many gold beads are in the bracelet?

10. To make mortar you mix 1 shovel of cement with 5 shovels of sand.

How much sand do you need to make 30 shovels of mortar?

- 1) Here are the ingredients for making a vegetable soup for 6 people:

2 carrots 1 onion 800ml stock 50g lentils 4g thyme

Work out the amount of each ingredient for

- a) 12 people
- b) 9 people
- c) 30 people.
- 2) Here are the ingredients for making apple crumble for 4 people:

80g plain flour 60g ground almonds 90g sugar 60g butter 4 apples

Work out the amount of each ingredient for

- a) 2 people
- b) 6 people
- c) 18 people.
- 3) Here are the ingredients for making 1500 ml of parsnip soup:

450g parsnips 300g leeks 150g bramley apples 3 onions 1 $\frac{1}{2}$ pints of chicken stock
--

Work out the amount of each ingredient for

- a) 500 ml of soup
- b) 1000 ml of soup
- c) 2500 ml of soup.

1) Find the value of the following:

(write down all the figures on your calculator display)

a) $(0.3 + 2.8)^2$

b) $2.7^2 + 3.9^2$

c) $4.5^2 - \sqrt{53}$

d) $6 \times \sqrt{(37 \div 4)}$

2) Find the value of the following:

(write your answers correct to 1 decimal place)

a) $5.6^3 + 11.2$

b) $87.4 \div (\sqrt{39} + 3)$

c) $\frac{\sqrt{3412}}{4.3^2}$

d) $\frac{15^2 - 12^2}{\sqrt{9.6 - 3.87}}$

3) Work out

$$\sqrt{16.75} + 1.53^2$$

a) Write down all the figures on your calculator display.

b) Write your answer to part (a) correct to 1 decimal place.

4) Work out

$$(2.4 \times 1.9)^2 \times 2.03$$

Write down all the figures on your calculator display.

5) Use your calculator to work out the value of

$$\frac{7.34 \times 4.71}{5.63 + 11.89}$$

a) Write down all the figures on your calculator display.

b) Write your answer to part (a) to an appropriate degree of accuracy.

Real-Life Money Questions

- 1) Lance goes on holiday to France.
The exchange rate is $\text{£}1 = 1.40$ Euros.
He changes $\text{£}350$ into Euros.
- a) How many Euros should he get?
- In France, Lance buys a digital camera for 126 Euros.
- b) Work out the cost of the camera in pounds.
- 2) Whilst on holiday in Spain, Gemma bought a pair of sunglasses for 77 Euros.
In England, an identical pair of sunglasses costs $\text{£}59.99$.
The exchange rate is $\text{£}1 = 1.40$ Euros.
- In which country were the glasses the cheapest, and by how much?
Show all your working.
- 3) Luke buys a pair of trainers in Switzerland.
He can pay either 86 Swiss Francs or 56 Euros.
The exchange rates are:
 $\text{£}1 = 2.10$ Swiss Francs
 $\text{£}1 = 1.40$ Euros
- Which currency should he choose to get the best price, and how much would he save?
Give your answer in pounds (£).
- 4) The total cost of 5 kg of potatoes and 2 kg of carrots is $\text{£}4.88$.
3 kg of potatoes cost $\text{£}1.98$.
- Work out the cost of 1 kg of carrots.
- 5) The cost of 4 kg of bananas is $\text{£}5.80$.
The total cost of 3 kg of bananas and 1.5 kg of pears is $\text{£}5.61$.
- Work out the cost of 1 kg of pears.

1. Write down the first 5 terms and the 10th term of the following sequences:

eg. $2n + 1$ $3, 5, 7, 9, 11, \dots, 21$

a) $2n + 2$

d) $7n$

b) $3n + 1$

e) $3n - 1$

c) $n + 3$

f) $7n - 3$

2. Find the n^{th} term of the following sequences:

a) 5, 10, 15, 20...

d) 22, 18, 14, 10...

b) 5, 8, 11, 14...

e) -3, 3, 9, 15...

c) 1, 8, 15, 22...

f) 4, -1, -6, -11...

3. Here are some patterns made from sticks.



Pattern 1

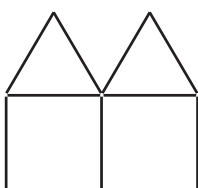

Pattern 2

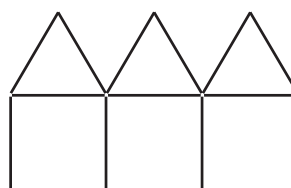

Pattern 3

a) Draw pattern 4 in the space, below..

b) How many sticks are used in

(i) pattern 10

(ii) pattern 20

(iii) pattern 50

c) Find an expression, in terms of n , for the number of sticks in pattern number n .

d) Which pattern number can be made using 301 sticks?

- 1) Work out the value of $5x$ when
 - a) $x = 2$
 - b) $x = 6$
 - c) $x = 10$
- 2) Work out the value of $3x$ when
 - a) $x = -2$
 - b) $x = 10$
 - c) $x = -12$
- 3) Work out the value of x^2 when
 - a) $x = 3$
 - b) $x = -4$
 - c) $x = -10$
- 4) Work out the value of $2x^2$ when
 - a) $x = 5$
 - b) $x = -4$
 - c) $x = 10$
- 5) Work out the value of $3x + 5$ when
 - a) $x = 2$
 - b) $x = 6$
 - c) $x = -1$
- 6) Work out the value of $4 + 2x$ when
 - a) $x = 7$
 - b) $x = -1$
 - c) $x = -3$
- 7) Work out the value of $3x + 2y$ when
 - a) $x = 1$ and $y = 2$
 - b) $x = 4$ and $y = 3$
 - c) $x = 5$ and $y = -4$
- 8) Work out the value of $6x - 3y$ when
 - a) $x = 2$ and $y = 1$
 - b) $x = 1$ and $y = -2$
 - c) $x = -3$ and $y = 4$
- 9) Work out the value of $3x^2 + 4y$ when
 - a) $x = 1$ and $y = 5$
 - b) $x = -2$ and $y = 2$
 - c) $x = 3$ and $y = -2$
- 10) Using the formula $P = H \times R$, where P is the total pay, H is the number of hours worked, and R is the hourly rate of pay.
Work out the total pay (P) of the following people:
 - a) Betty worked 10 hours at £7 per hour
 - b) John worked 15 hours and is paid £9 per hour
 - c) Mike worked for 90 minutes at £16 an hour.
- 11) The equation of a straight line is given as $y = 3x + 2$
 - a) Work out the value of y when
 - (i) $x = 0$
 - (ii) $x = 1$
 - (iii) $x = 2$
 - b) What is the value of x when $y = 17$?

- 1) Line PQ is parallel to line RS
 If angle PQR is equal to 36°
 a) What is the size of angle QRS?
 b) Give a reason for your answer.

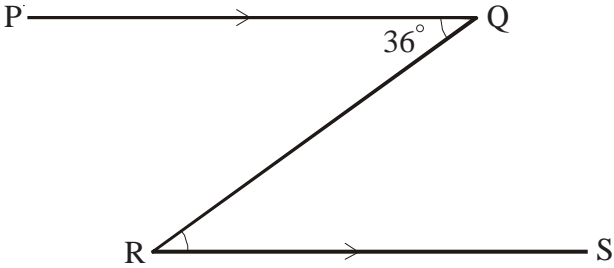

- 2) Line DCE is parallel to line AB
 a) Find the size of angle ABC
 b) Find the size of angle DCA
 c) Calculate the size of angle ACB

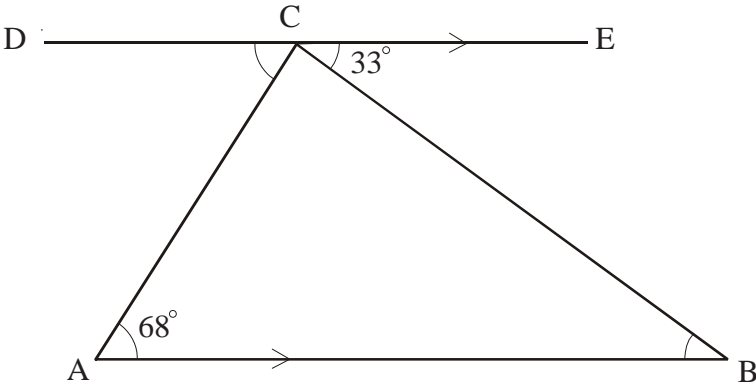

- 3) a) Find the size of angle DBF
 b) Find the size of angle HGC

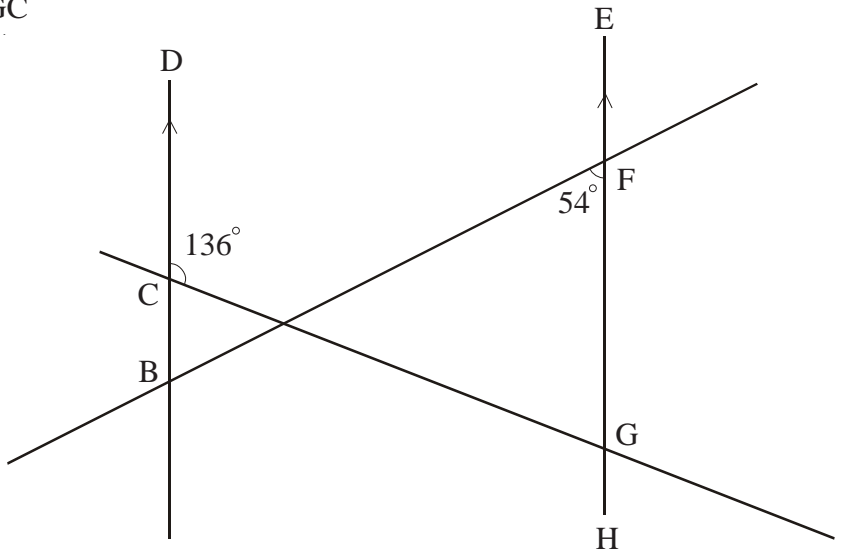

Angle Sum of Triangles - 1 of 2

1) Work out the size of the angles marked with letters.

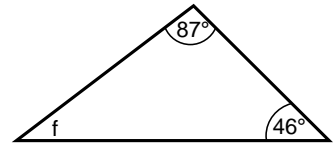
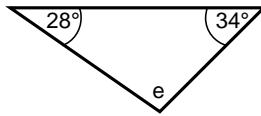
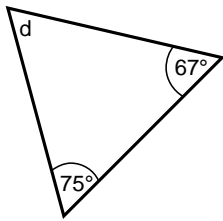
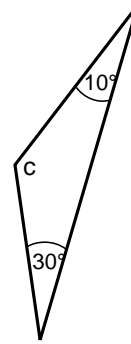
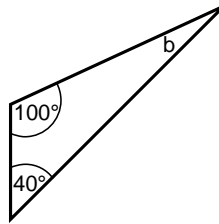
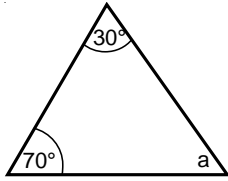

2) Work out the size of the angles marked with letters.

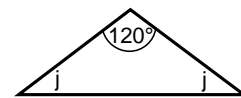
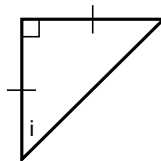
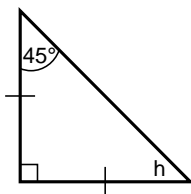
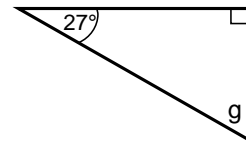
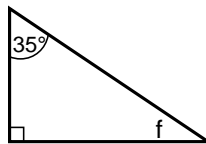
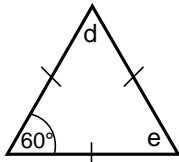
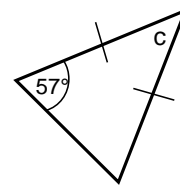
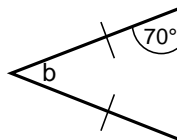
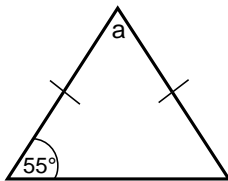

3) Work out the size of the angles marked with letters.

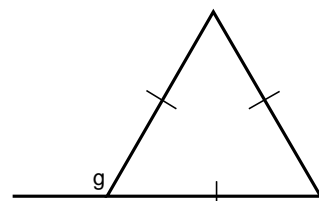
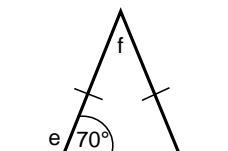
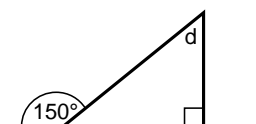
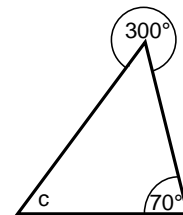
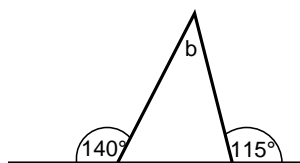
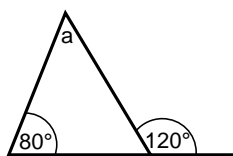

Angle Sum of Triangles - 2 of 2

- 1) ABC is a triangle.
- Find the size of angle A .
 - Triangle ABC is equilateral.
Explain why.

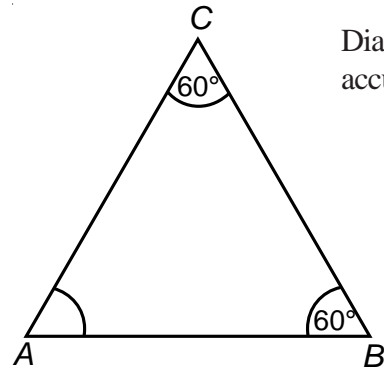

Diagram **NOT** accurately drawn

- 2) BCD is a triangle.
 ABC is a straight line.
Angle $CBD = 70^\circ$.
 $BD = CD$.
- Work out the value of x .
 - Give a reason for your answer.
 - Work out the value of y .
 - Give reasons for your answer.

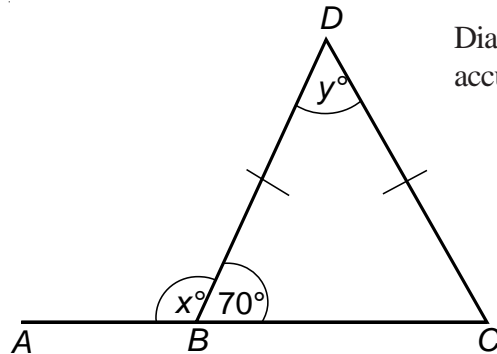

Diagram **NOT** accurately drawn

- 3) The diagram shows a 5-sided shape.
All the sides of the shape are equal in length.
- Find the value of x .
 - Give a reason for your answer.
 - Work out the value of y .
 - Explain your answer.

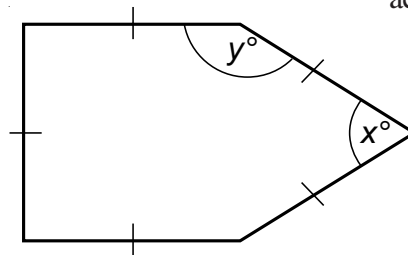
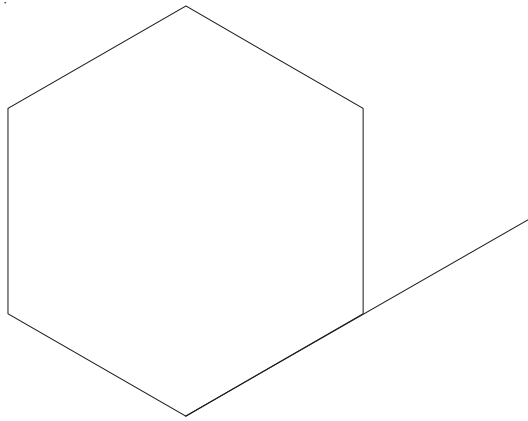

Diagram **NOT** accurately drawn

Angles of Regular Polygons

1)



- a) Work out the size of an **exterior** angle of a regular hexagon.
- b) Work out the size of an **interior** angle of a regular hexagon.

2)

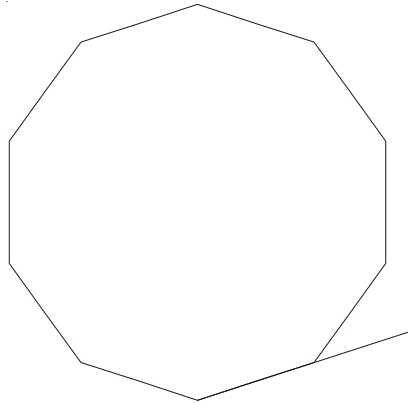

- a) Name the regular polygon, above.
- b) Work out the size of an **exterior** angle and of an **interior** angle for this polygon.

- 3) The size of each **exterior** angle of a regular polygon is 90° .
Work out the number of sides of the regular polygon.
- 4) The size of each **exterior** angle of a regular polygon is 40° .
Work out the number of sides of the regular polygon.
- 5) The size of each **interior** angle of a regular polygon is 120° .
Work out the number of sides of the regular polygon.
- 6) The size of each **interior** angle of a regular polygon is 150° .
Work out the number of sides of the regular polygon.

Diagrams **NOT** accurately drawn

- 1) Find the areas of the following shapes.
Take π to be 3.14

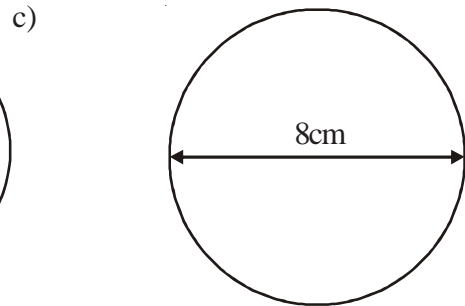
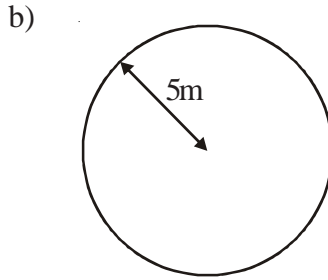
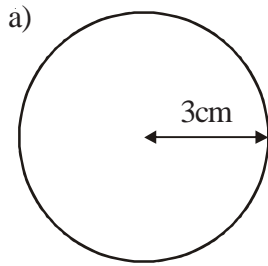

- 2) Work out the areas of the following shapes.

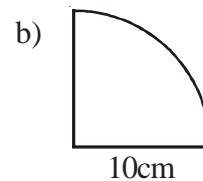
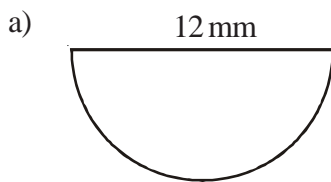

- 3) The diagram shows a circular garden comprising a rectangular pond enclosed by grass. The circular garden has a diameter of 10 m. The rectangular pond measures 8 m by 6 m.

Work out the area of the garden covered in grass.
Take π to be 3.14 and give your answer to the nearest m^2 .

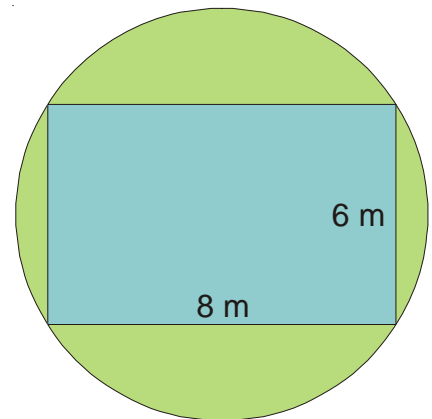

- 4) The **radius** of the top of a circular table is 60 cm. The table also has a circular base with **diameter** 30 cm.
- a) Work out the area of the top of the table.
- b) Work out the area of the base of the table.



- 5) The diagram shows a shape, made from a semi-circle and a rectangle. The diameter of the semi-circle is 13 cm. The length of the rectangle is 17 cm.

Calculate the area of the shape.
Give your answer correct to 3 significant figures.

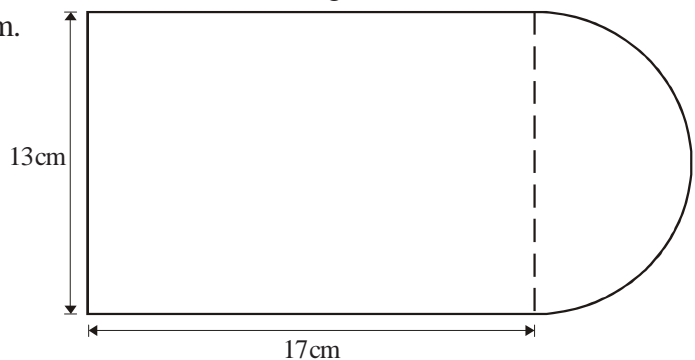

Circumference of Circles

Diagrams **NOT** accurately drawn

- 1) Find the circumference of the following shapes.
Take π to be 3.14.

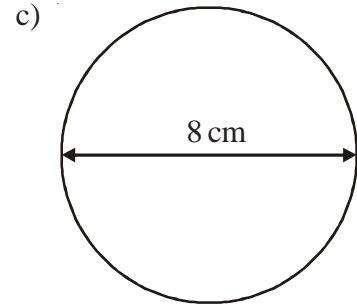
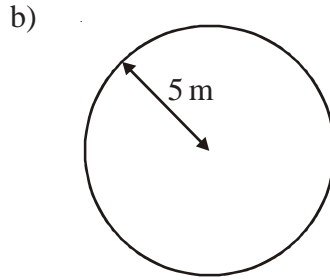
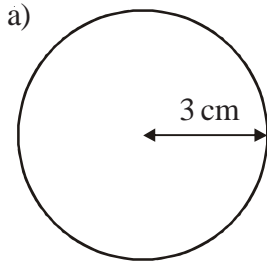

- 2) Work out the perimeter of the following shapes, taking π to be 3.14.

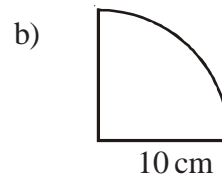
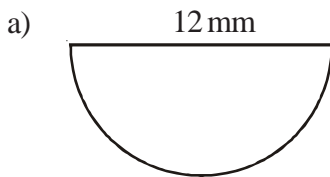

- 3) The **radius** of the top of a circular table is 60 cm.
The table also has a circular base with **diameter** 30 cm.
- a) Work out the circumference of the top of the table.
Let π be 3.14
- b) Work out the circumference of the base of the table.
Let π be 3.14



- 4) The diameter of a wheel on Kyle's bicycle is 0.75 m.
- a) Calculate the circumference of the wheel.
Give your answer correct to 2 decimal places.

Kyle cycles 2000 metres.

- b) Using your answer in (a), calculate the number of complete turns the wheel makes.

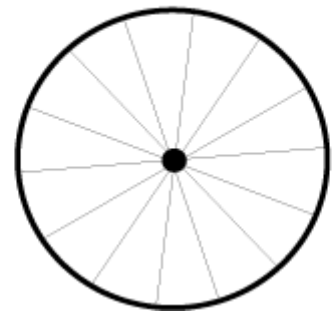

- 5) The diagram shows a shape, made from a semi-circle and a rectangle.
The diameter of the semi-circle is 12 cm.
The length of the rectangle is 15 cm.

Calculate the perimeter of the shape.
Give your answer correct to 3 significant figures.

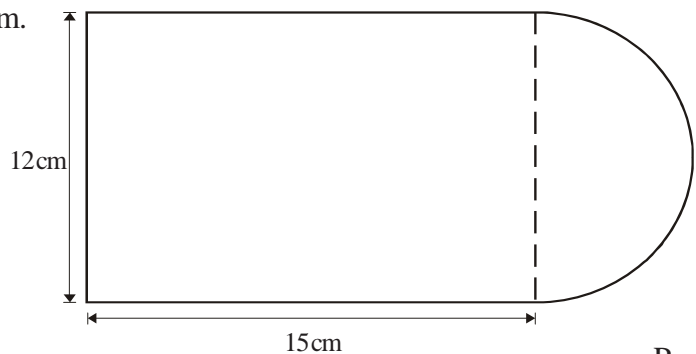

Area of Compound Shapes

1) Find the area of each shape.

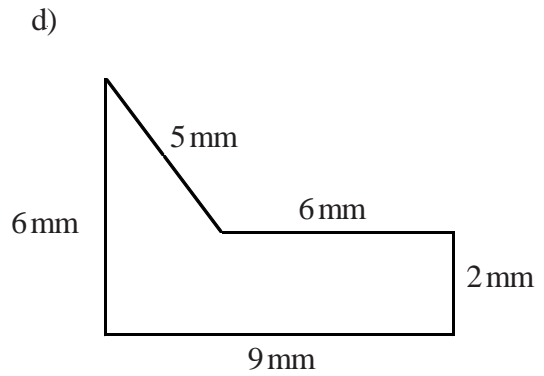
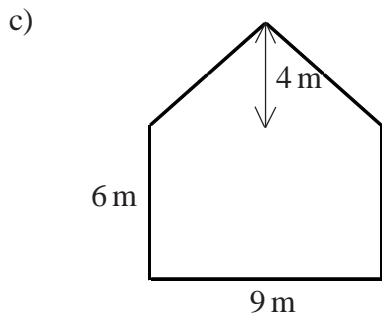
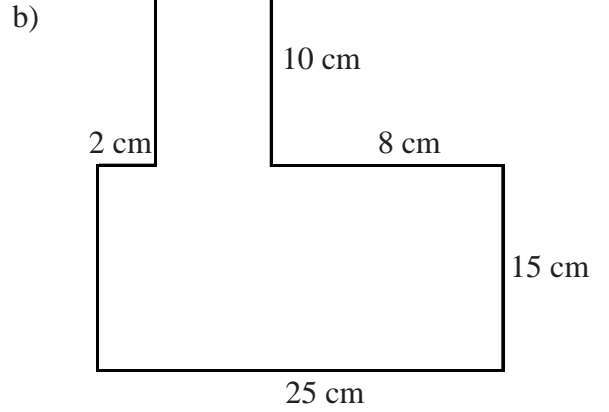
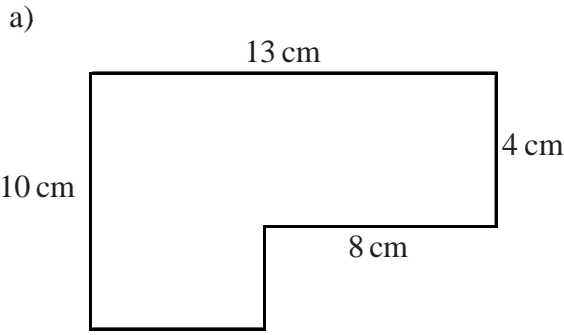

2) Find the shaded area of each shape.

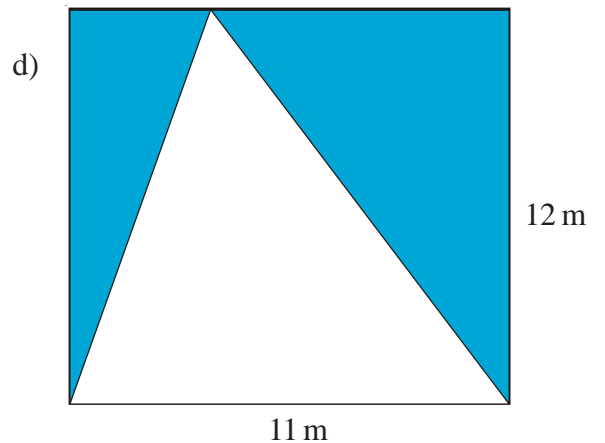
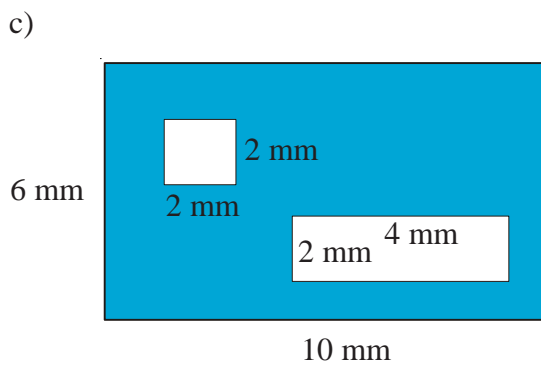
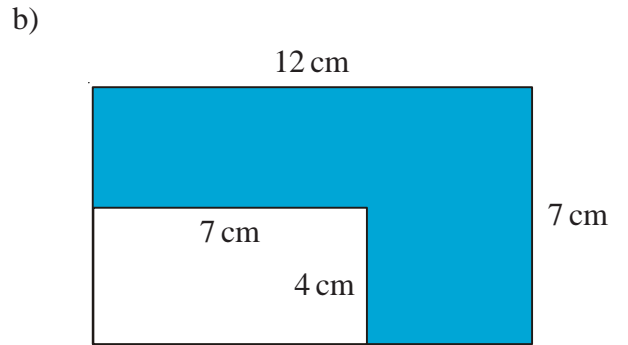
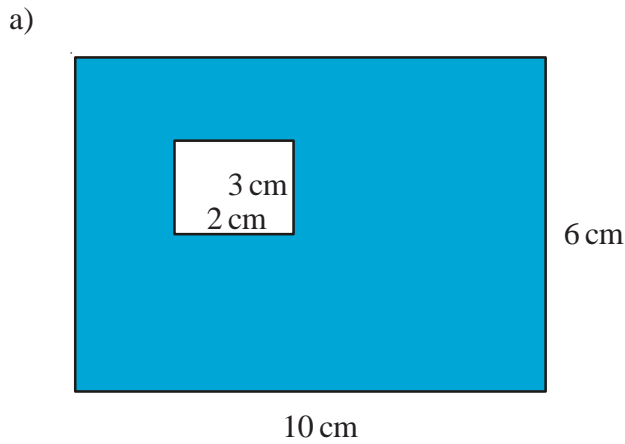

Rotations

- 1) a) Rotate triangle T 90° anti-clockwise about the point (0, 0).
Label your new triangle U
- b) Rotate triangle T 180° about the point (2, 0).
Label your new triangle V

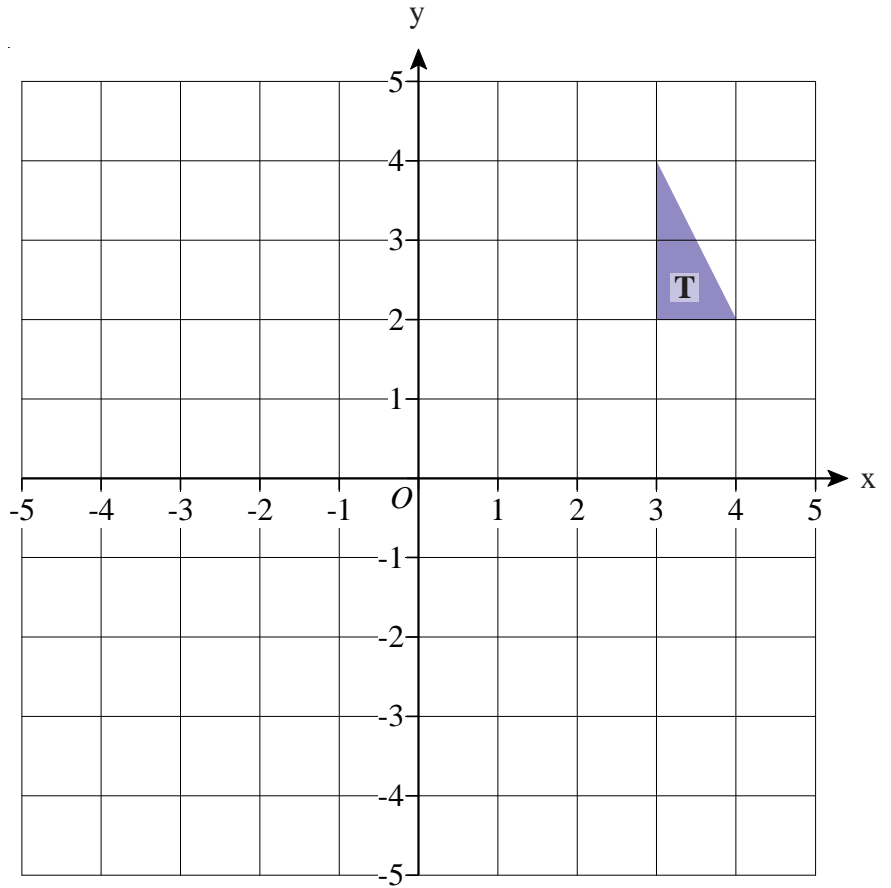

- 2) Describe fully the single transformation which maps triangle T to triangle U.

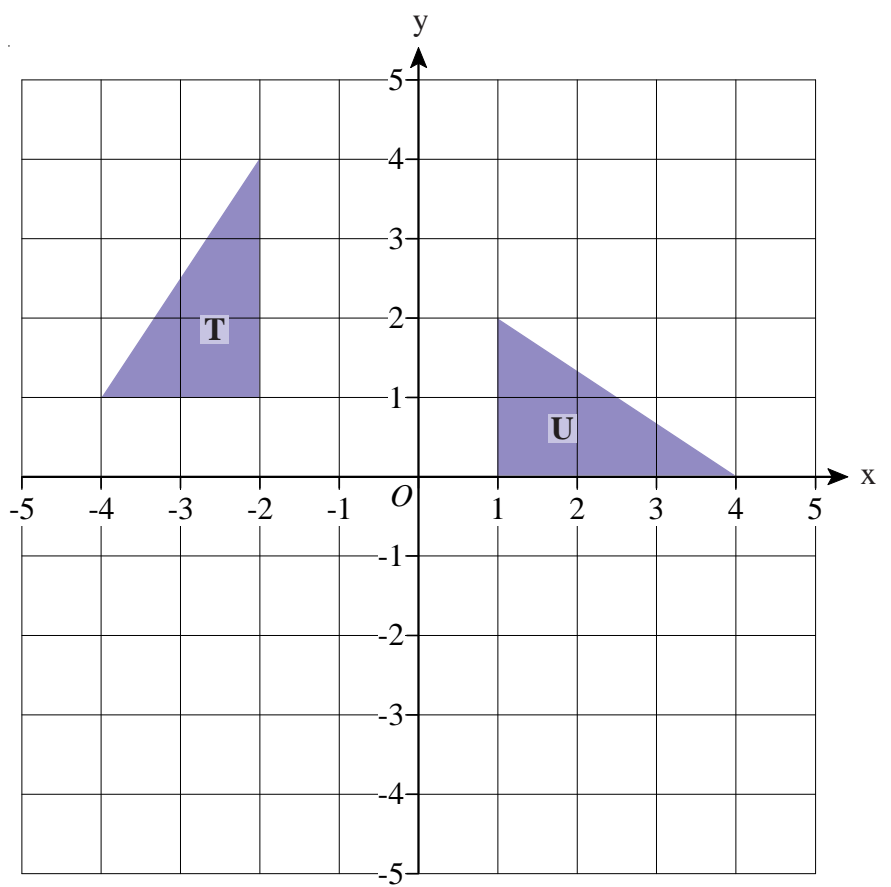

Reflections

- 1) a) Reflect triangle T in the x axis.
Label your new triangle U.

- b) Reflect triangle T in the line with equation $y = -x$.
Label your new triangle V.

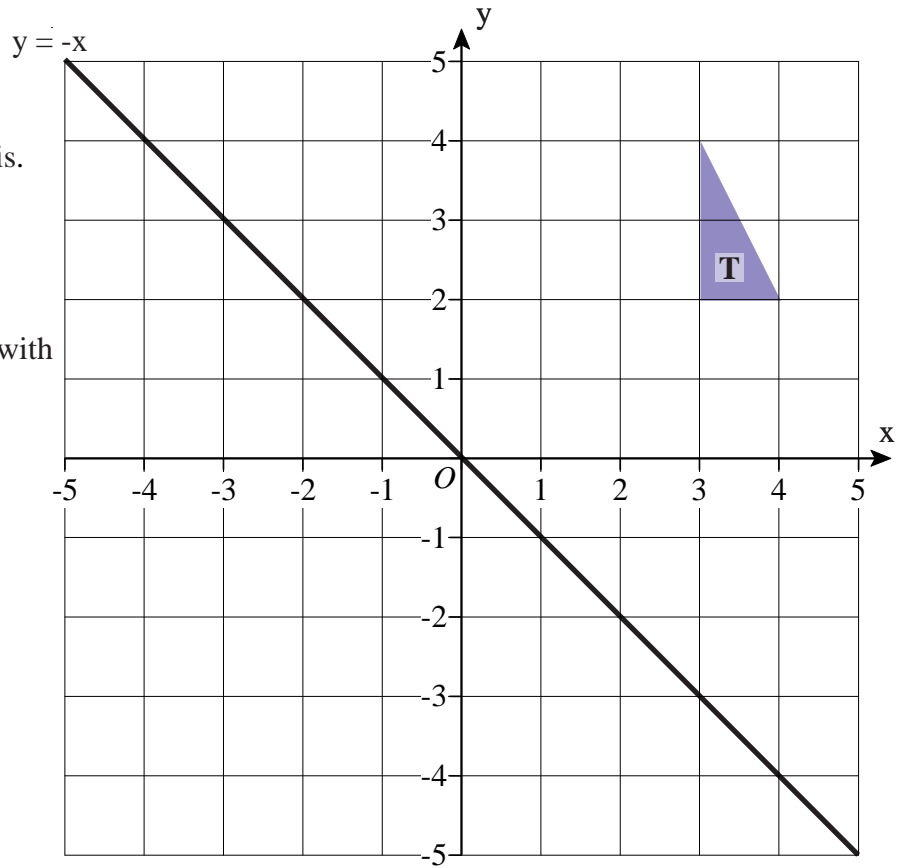

- 2) a) Describe fully the single transformation which maps triangle T to triangle U.

- b) Describe fully the single transformation which maps triangle T to triangle V.

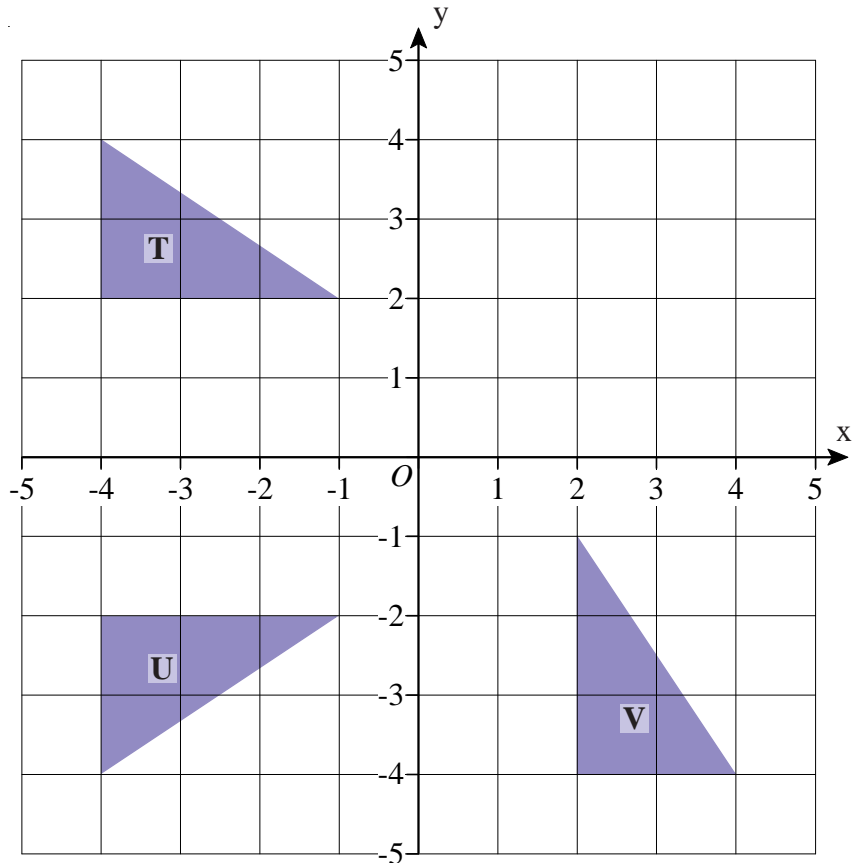

Enlargements

- 1) a) Enlarge triangle T by scale factor 2 using point $(-5, 2)$ as the centre of enlargement.
Label your new triangle U.
- b) Enlarge triangle V by scale factor a half using the point $(-2, -3)$ as the centre of enlargement.
Label your new triangle W.

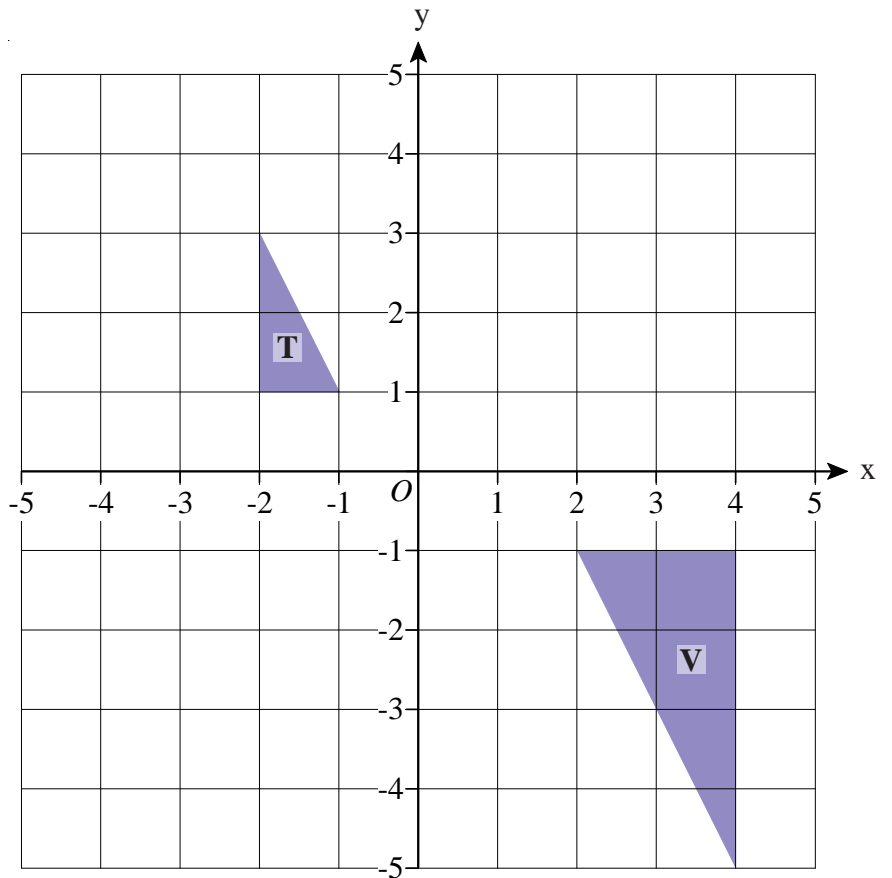

- 2) Describe fully the single transformation which maps triangle S to triangle T

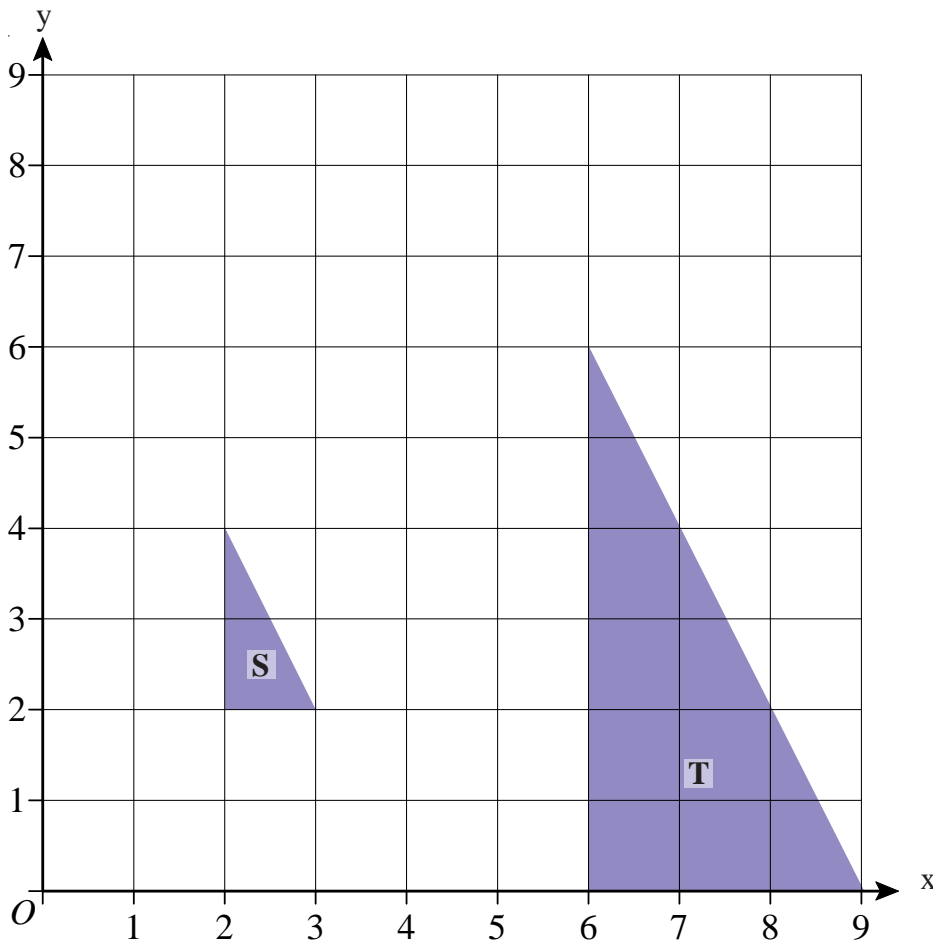

Translations

1) a) Translate triangle T by vector $\begin{bmatrix} -4 \\ 2 \end{bmatrix}$ and label it U

b) Translate triangle T by vector $\begin{bmatrix} 3 \\ -2 \end{bmatrix}$ and label it V

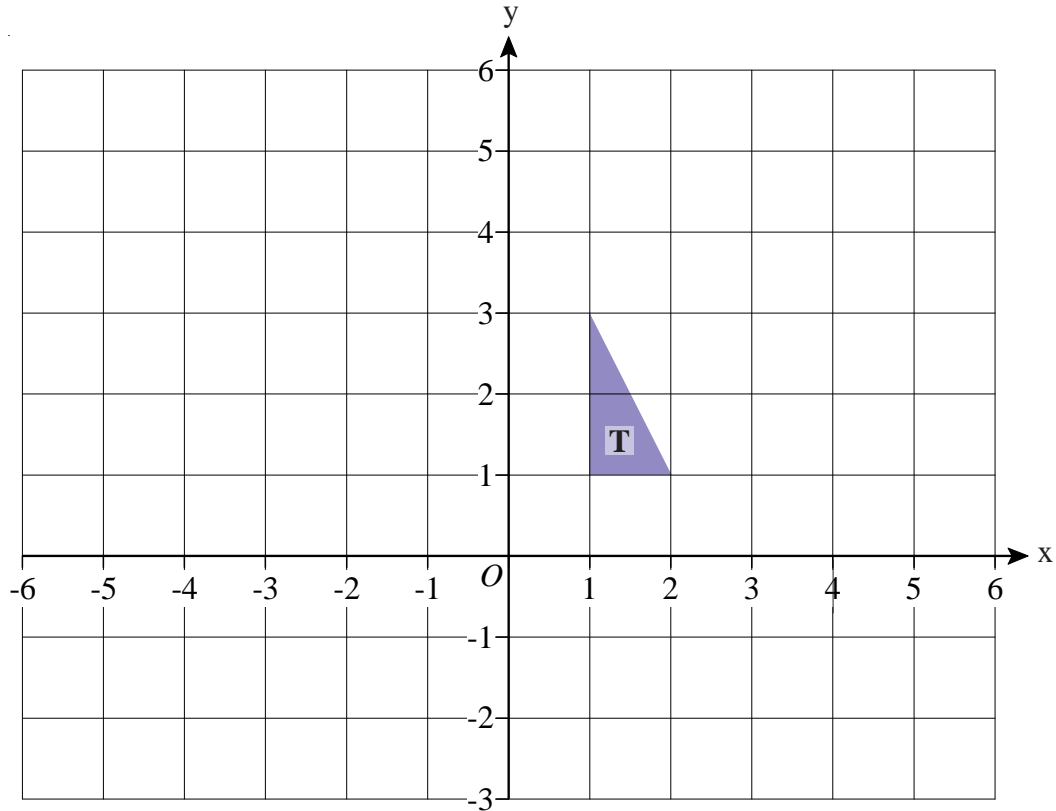

2) a) Describe fully the single transformation which maps triangle A to triangle B.

b) Describe fully the single transformation which maps triangle A to triangle C.

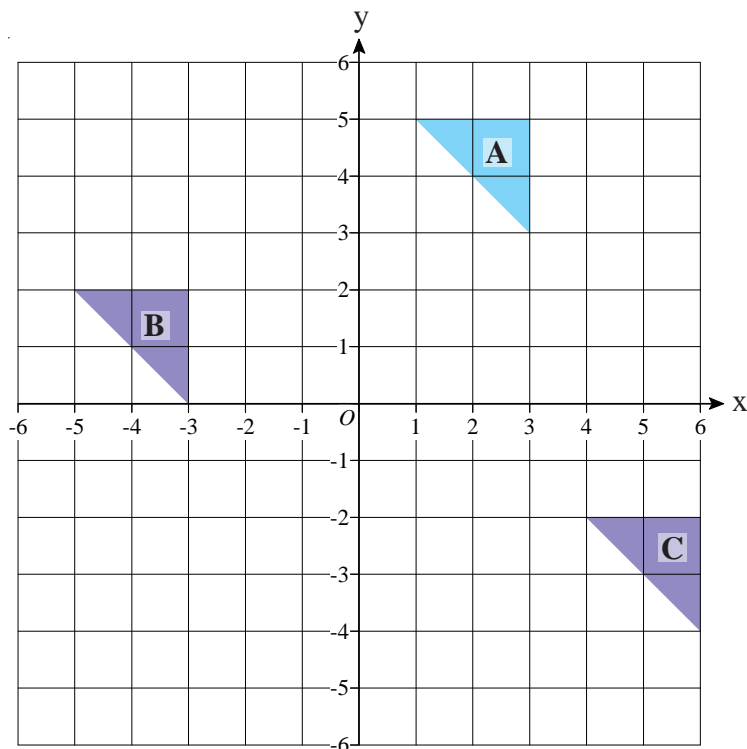

Find the Mid-Point of a Line

- 1) Find the midpoint of A and B where A has coordinates $(-2, 5)$ and B has coordinates $(4, -1)$.

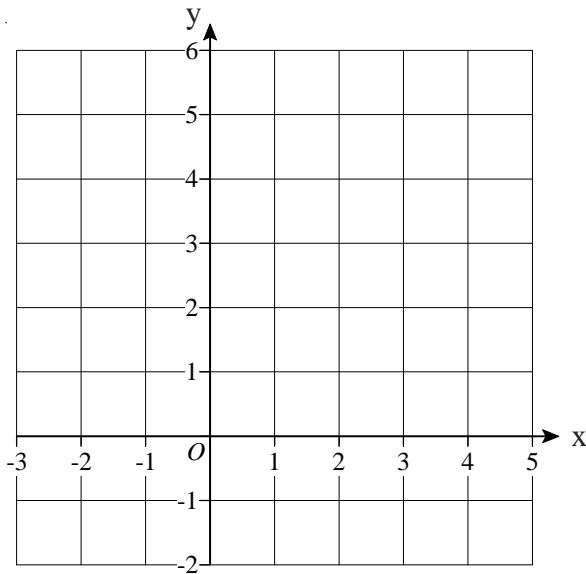

- 2) Find the midpoint of A and B where A has coordinates $(2, 0)$ and B has coordinates $(8, 6)$.
- 3) Find the midpoint of A and B where A has coordinates $(-4, -2)$ and B has coordinates $(2, 4)$.
- 4) Find the midpoint of A and B where A has coordinates $(-3, -2)$ and B has coordinates $(7, 5)$.
- 5) Find the midpoint of A and B where A has coordinates $(2, -5)$ and B has coordinates $(7, 4)$.
- 6) Find the midpoint of A and B where A has coordinates $(-7, -4)$ and B has coordinates $(-2, -1)$.
- 7) The midpoint of A and B is at $(1, 3)$.
The coordinates of A are $(-2, 4)$.
Work out the coordinates of B.
- 8) The midpoint of A and B is at $(3.5, 2.5)$.
The coordinates of A are $(2, 5)$.
Work out the coordinates of B.

1) Measure the following angles:

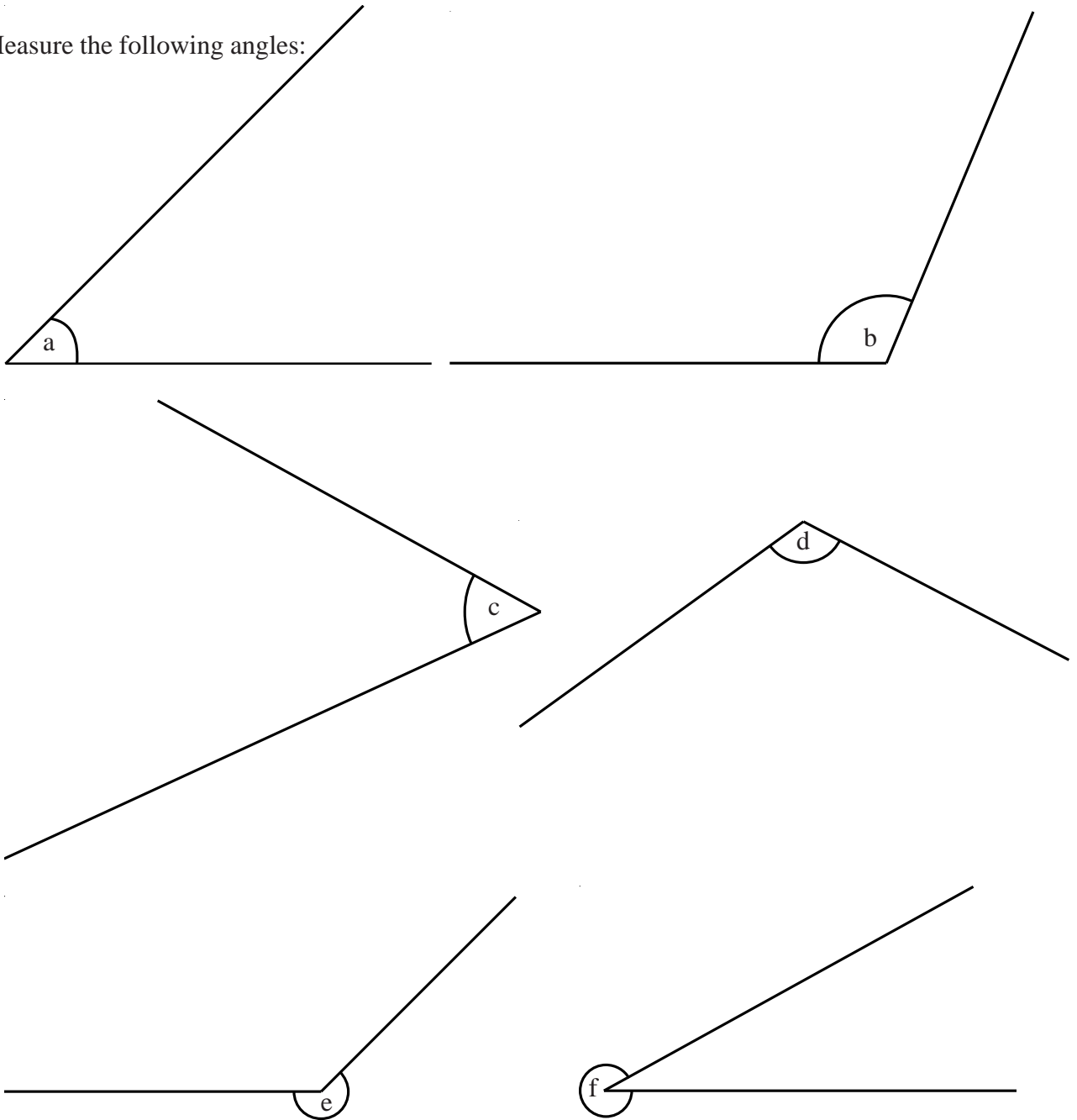

2) Draw the following angles:

a) angle $ABC = 60^\circ$

b) angle $PQR = 127^\circ$

c) angle $XYZ = 275^\circ$

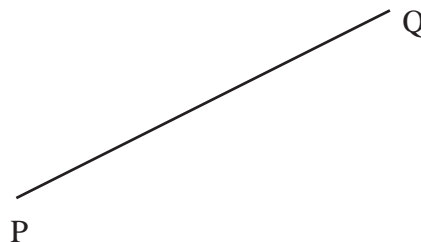

Drawing Triangles

- 1) The diagram shows the sketch of triangle ABC.

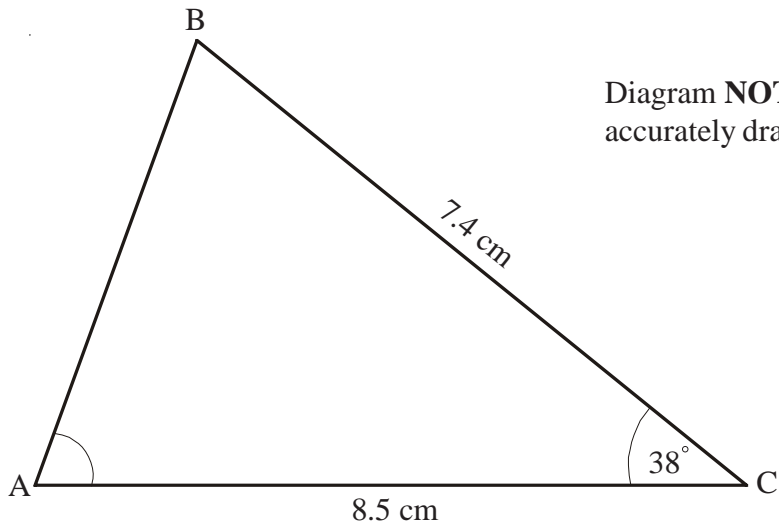

Diagram **NOT** accurately drawn

BC = 7.4 cm
 AC = 8.5 cm
 Angle C = 38°

- a) Make an accurate drawing of triangle ABC.
 - b) Measure the size of angle A on your diagram.
- 2) Use ruler and compasses to **construct** an equilateral triangle with sides of length 6 centimetres.
 You must show all construction lines.

- 3) The diagram shows the sketch of triangle PQR.

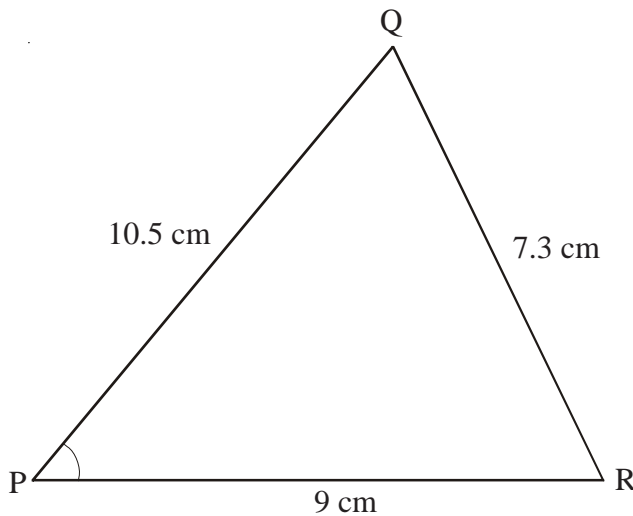
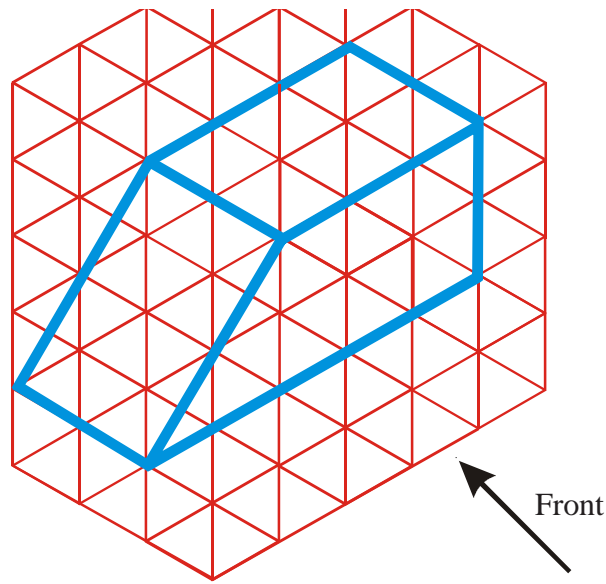

Diagram **NOT** accurately drawn

- a) Use ruler and compasses to make an accurate drawing of triangle PQR.
- b) Measure angle P.

The diagram shows a prism drawn on an isometric grid.



- a) On the grid below, draw the front elevation of the prism from the direction marked by the arrow.

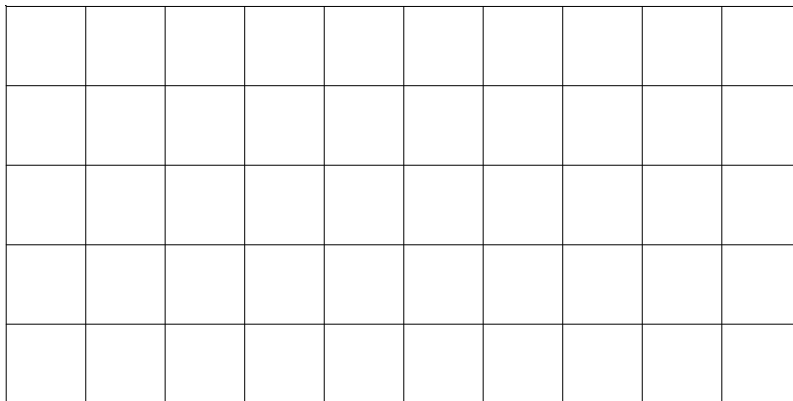

- b) On the grid below draw a plan of the prism.

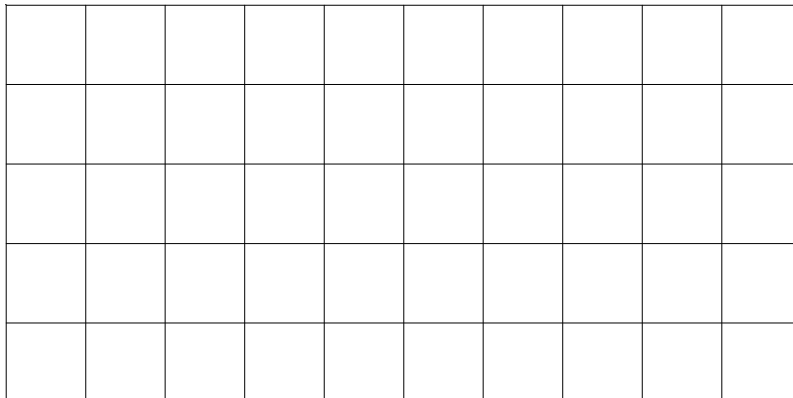

Nets

1) Sketch nets of these solids.

a)

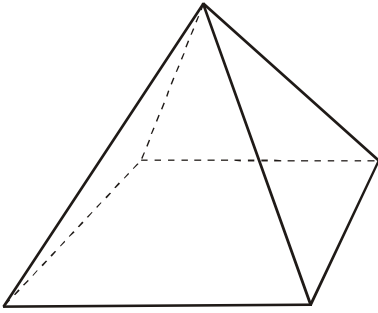

b)

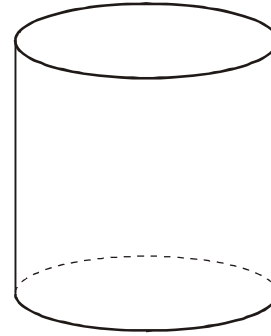

2) On squared paper draw accurate nets of these solids.

a)

Cube

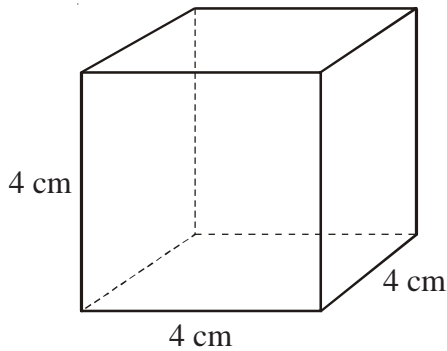

b)

Cuboid

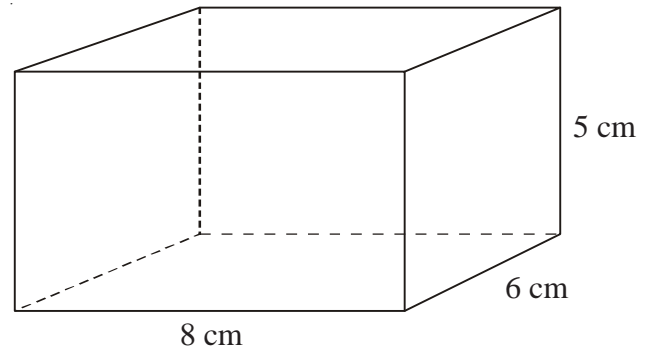

c)

Right-angled triangular prism

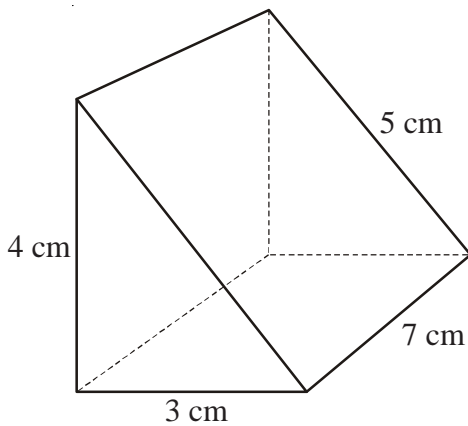

d)

Triangular prism

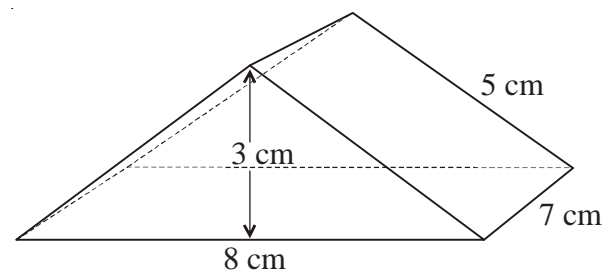

3) The two nets, below, are folded to make cubes.

Two other vertices will meet at the the dot, A. Mark them with As.
One other vertex will meet the dot B. Mark it with B.

a)

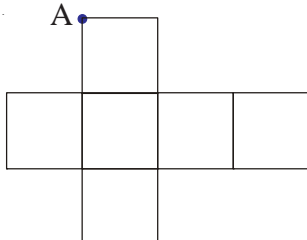

b)

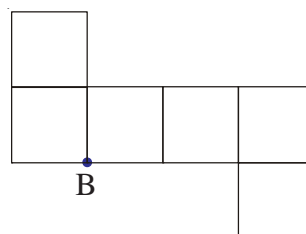

Symmetries

- 1) Draw all the lines of symmetry on the triangle and the rectangle.

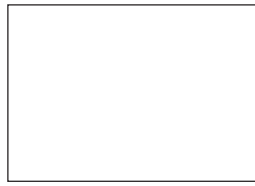
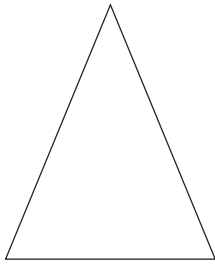

- 2) What is the order of rotational symmetry of the two shapes below.

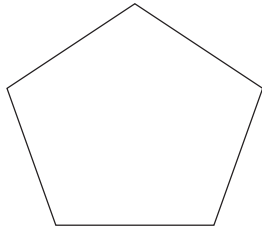

- 3) The diagram below, shows part of a shape.

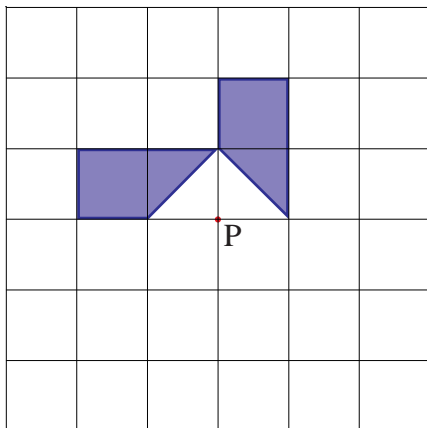

The shape has rotational symmetry of order 4 about point P.

Complete the shape.

- 4) On each of the shapes below, draw one plane of symmetry.

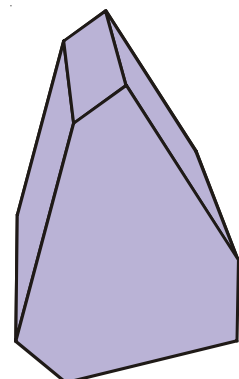
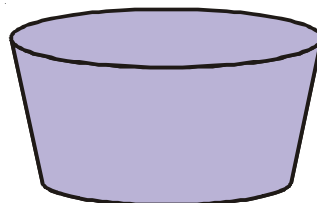
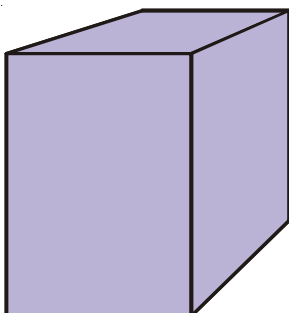

- 1) Claire wants to find how much time pupils spend on their homework. She hands out a questionnaire with the question

How much time do you spend on your homework?

A lot Not much

- a) Write down two things that are wrong with this question
-
-

- b) Design a suitable question she could use.

You should include response boxes.

- 2) Tony wants to know which type of programme pupils in his class like watching on TV.

Design a suitable data collection sheet he could use to gather the information.

- 3) Emma asked 20 people what was their favourite pet.

Here are their answers.

cat	cat	hamster	cat
mouse	hamster	cat	dog
dog	dog	snake	hamster
cat	cat	hamster	dog
cat	hamster	snake	cat

Design and complete a suitable data collection sheet that Emma could have used to collect and show this information.

Two-Way Tables

1. Billy has been carrying out a survey.
He asked 100 people the type of water they like to drink (still, sparkling or both).
Here are part of his results:

	Still	Sparkling	Both	Total
Male	26			53
Female		20	10	
Total			16	100

- a) Complete the two-way table.
- b) How many males were in the survey?
- c) How many females drink only still water?
- d) How many people drink only sparkling water?
2. 90 students each study one of three languages.
The two-way table shows some information about these students.

	French	German	Spanish	Total
Female				
Male		7		
Total	20	18		90

- 50 of the 90 students are male.
29 of the 50 male students study Spanish.

- a) Complete the two-way table.
- b) How many females study French?
- c) How many people study Spanish?

Pie Charts

- 1) Patrick asked some of his colleagues which was their favourite holiday destination. The table shows the results.

City	Frequency
Alicante	8
Paris	7
Ibiza	15
St Lucia	1
Biarritz	9

Draw a pie chart to illustrate the information.

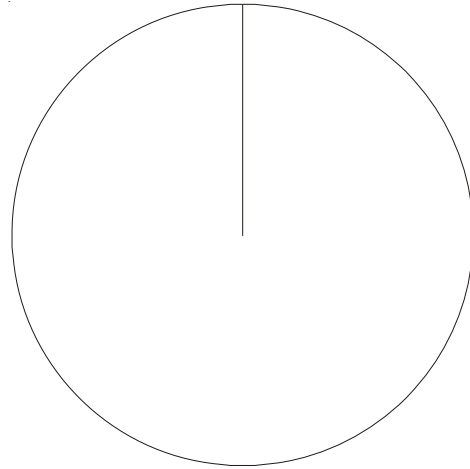

- 2) Brian asked 60 people which region their favourite rugby team came from. The table shows the results.

Region	Frequency
Southern England	9
London	23
Midlands	16
Northern England	12
Total	60

Draw a pie chart to illustrate the information.

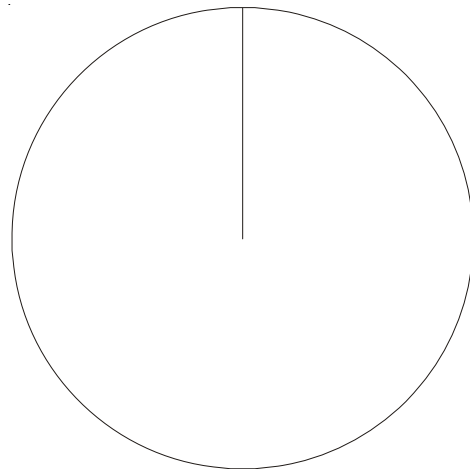

- 3) Sophie represents her monthly expenses using a pie chart.

Diagram accurately drawn

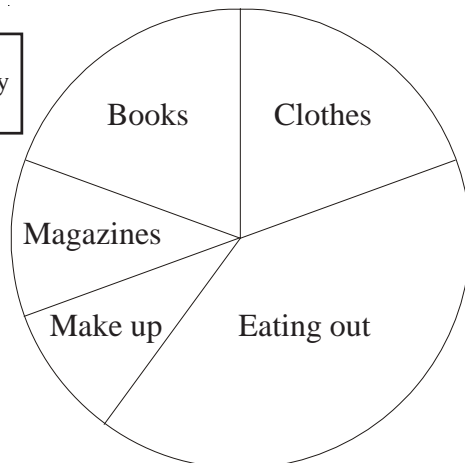

Numbers from her table have been rubbed out by mistake.

Use the pie chart to complete the table.

		Angle
Clothes	£35	
Eating out		
Make up	£17	34°
Magazines		
Books		
Total	£180	

Scatter Graphs

- 1) The scatter graph shows some information about the marks of six students. It shows each student's marks in Maths and Science.

The table below shows the marks for four more students.

Maths	22	8	17	26
Science	30	12	24	24

- On the scatter graph, plot the information from the table.
- Draw a line of best fit.
- Describe the correlation between the marks in Maths and the marks in Science.

Another student has a mark of 18 in Science.

- Use the line of best fit to estimate the mark in Maths of this student.

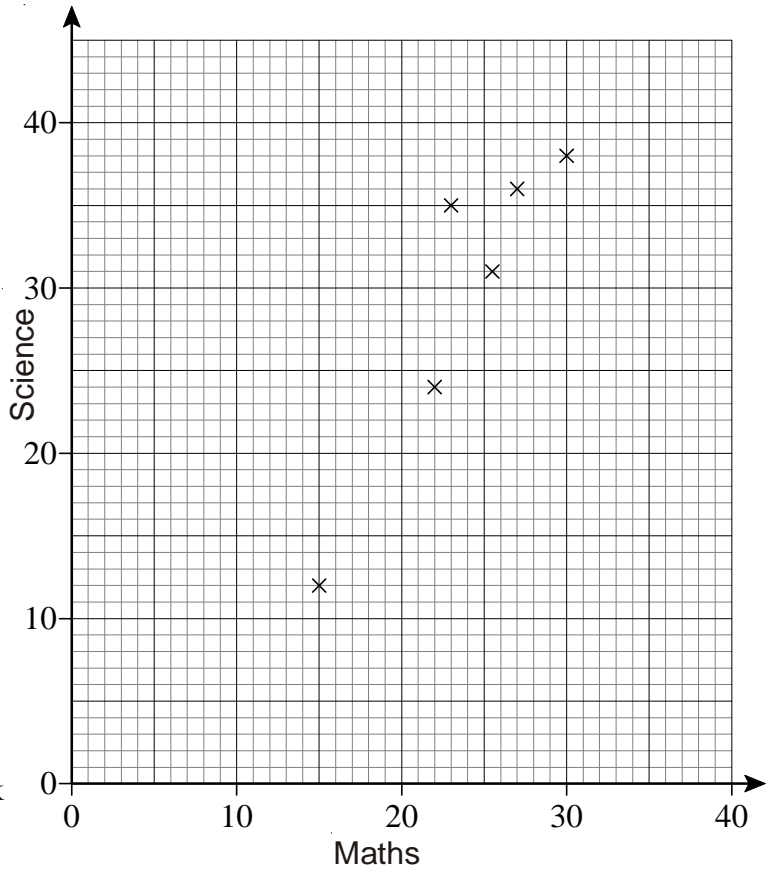

- 2) The table below shows the average daily number of hours sleep of 10 children.

Age (years)	4	2	5	1	9	6	8	7	10	1.5
Number of hours sleep	14	13	12.5	15	10	12.5	10.8	12	11	14

The first five results have been plotted on the scatter diagram.

- Plot the next five points.
- Draw a line of best fit.
- Describe the relationship between the age of the children and their number of hours sleep per day.
- Use your scatter graph to estimate the number of hours sleep for a 3 year old child.

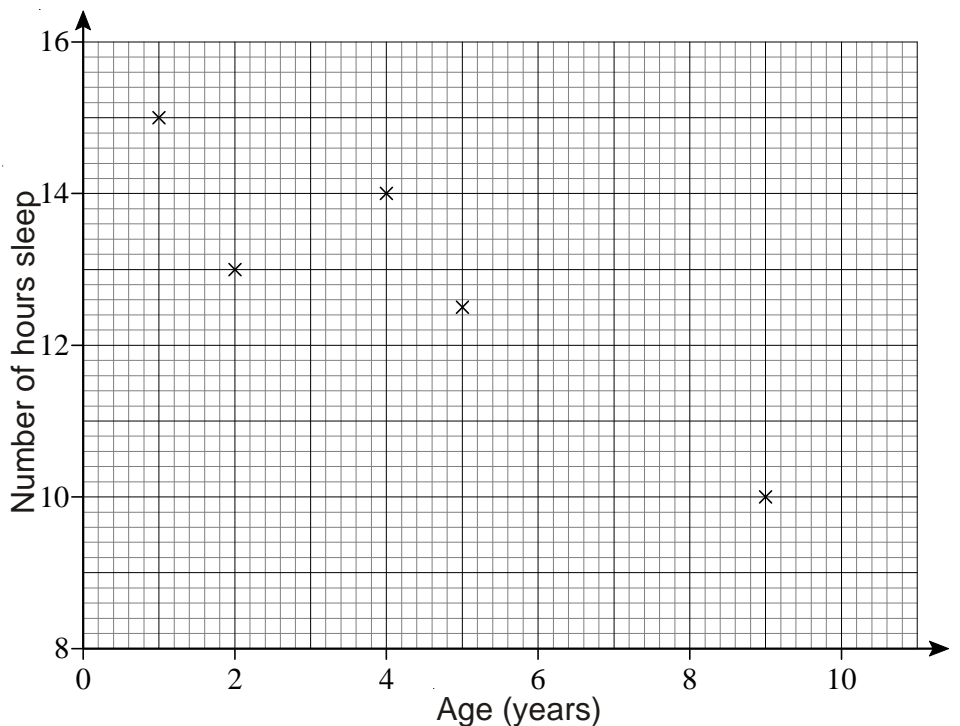

Frequency Diagrams

A class of pupils is asked to solve a puzzle.

The frequency table below shows the times taken by the pupils to solve the puzzle.

Time (t) in min	Frequency
$0 < t \leq 5$	3
$5 < t \leq 10$	4
$10 < t \leq 15$	5
$15 < t \leq 20$	7
$20 < t \leq 25$	5

a) Draw a frequency diagram to show this information.

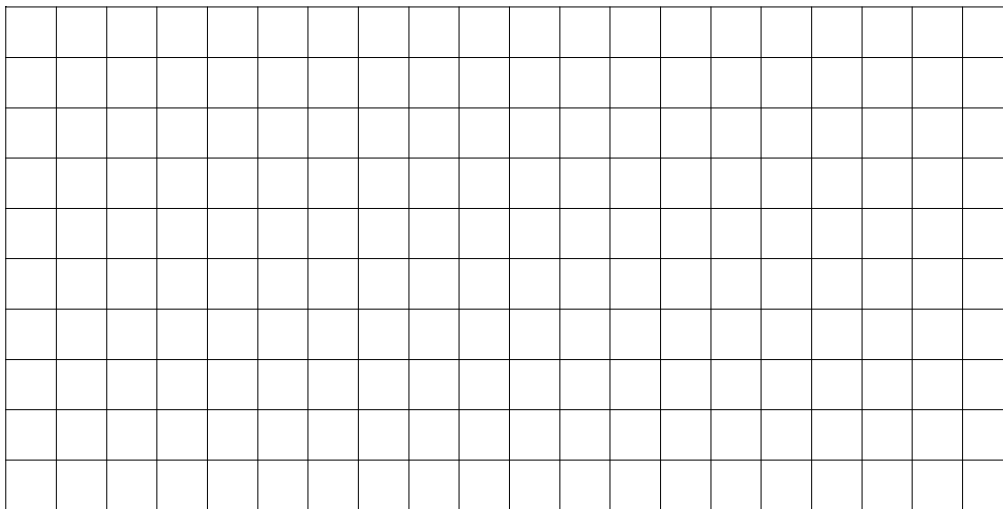

b) Draw a frequency polygon to show this information.

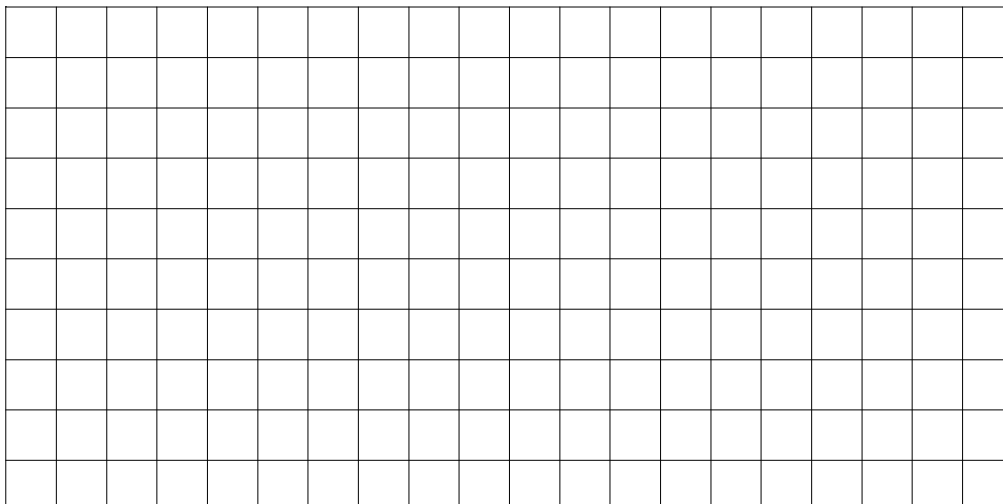

- 1) 16 students sat a Maths test.

Here are their marks:

64	72	39	45	49	67	73	50
73	44	55	77	51	62	64	79

Draw a stem and leaf diagram to show this information.

- 2) Pat is carrying out a survey on how tall pupils in her class are.

Here are their heights in cm:

173	162	170	169	163	173	156
159	161	168	177	182	170	169

Draw a stem and leaf diagram to show this information.

- 3) The stem and leaf diagram below, shows information about the times, in minutes, it takes a group of people to eat their breakfast.

0		5	7	9		
1		0	0	5	8	8
2		0	2	3	5	7
3		2	5			

Key: 1|0 represents 10 minutes.

- How many people are in the group?
- How many people spend 15 minutes or more eating their breakfast?
- Find the median time that it took to eat breakfast.

- 1) Three coins are flipped.
 - a) How many possible outcomes are there?
 - b) List all the possible outcomes.

- 2) Two coins are flipped and a dice is rolled.
 - a) How many possible outcomes are there?
 - b) List all the possible outcomes.

Mutually Exclusive Events

- 1) If the probability of passing a driving test is 0.54, what is the probability of failing it?

- 2) The probability that a football team will win their next game is $\frac{2}{11}$. The probability they will lose is $\frac{3}{11}$. What is the probability the game will be a draw?

- 3) On the school dinner menu there is only ever one of four options. Some of the options are more likely to be on the menu than others. The table shows the options available on any day, together with three of the probabilities.

Food	Curry	Sausages	Fish	Casserole
Probability	0.36	0.41		0.09

- a) Work out the probability of the dinner option being Fish.
 - b) Which option is most likely?
 - c) Work out the probability that it is a Curry or Sausages on any particular day.
 - d) Work out the probability that it is **not** Casserole.
-
- 4) Julie buys a book every week. Her favourite types are Novel, Drama, Biography and Romance. The table shows the probability that Julie chooses a particular type of book.

Type of book	Novel	Drama	Biography	Romance
Probability	0.24	0.16	x	x

- a) Work out the probability that she will choose a Novel or a Drama.
- b) Work out the probability that she will choose a Biography or a Romance.

The probability that she will choose a Biography is the same as the probability she will choose a Romance.

- c) Work out the probability that she will choose a Biography.

Overview of Percentages

With a calculator

- 1) Find the following to the nearest penny:
- 23% of £670
 - 12% of £580
 - 48% of £64
 - 13% of £7.50
 - 87% of £44
 - 15.7% of £7000
 - 23.8% of £980
 - 34% of £16.34
 - 48.6% of £971.26
 - 78.24% of £12.82
 - 42.15% of £7876.42
 - 0.57% of £60000

Without a calculator

- 2) Find the following:
- 10% of £700
 - 10% of £400
 - 10% of £350
 - 10% of £530
 - 10% of £68
 - 10% of £46
 - 10% of £6.50
 - 10% of £12.20
 - 20% of £600
 - 30% of £900
 - 60% of £800
 - 20% of £650
 - 40% of £320
 - 15% of £300
 - 15% of £360
 - 65% of £12000
 - 45% of £64
 - 85% of £96
 - 17.5% of £800
 - 17.5% of £40
 - 17.5% of £8.80

With a calculator

- 3) Change the following to percentages:
- 6 out of 28
 - 18 out of 37
 - 42 out of 83
 - 24 out of 96
 - 73 out of 403
 - 234 out of 659
 - 871 out of 903
 - 4.7 out of 23
 - 6.9 out of 79
 - 14.8 out of 23.6
 - 65.8 out of 203.7
 - 12 out of 2314

Without a calculator

- 4) Change the following to percentages:
- 46 out of 100
 - 18 out of 50
 - 7 out of 25
 - 23 out of 25
 - 9 out of 20
 - 16 out of 20
 - 7 out of 10
 - 9.5 out of 10
 - 10 out of 40
 - 16 out of 40
 - 30 out of 40
 - 12 out of 40
 - 28 out of 80
 - 32 out of 80
 - 60 out of 80
 - 3 out of 5
 - 4 out of 5
 - 15 out of 75
 - 24 out of 75
 - 30 out of 75

No calculator

- 5) A shop gives a discount of 20% on a magazine that usually sells for £2.80. Work out the discount in pence.

With a calculator

- 6) A television costs £595 plus VAT at 17.5%.
Work out the cost of the television including VAT.

With a calculator

- 7) Peter has 128 trees in his garden. 16 of the trees are pear trees. What percentage of the trees in his garden are pear trees?

With a calculator

- 8) A battery operated car travels for 10m when it is first turned on. Each time it is turned on it travels 90% of the previous distance as the battery starts to run out. How many times does the car travel at least 8 metres?

With a calculator

- 9) Jane scored 27 out of 42 in a Maths test and 39 out of 61 in a Science test. What were her percentages in both subjects to 1 decimal place?

No calculator

- 10) In class 7A there are 7 girls and 18 boys. What percentage of the class are girls?

No calculator

- 11) A shop decides to reduce all the prices by 15%.
The original price of a pair of trainers was £70. How much are they after the reduction?

No calculator

- 12) VAT at 17.5% is added to the price of a car. Before the VAT is added it cost £18000.
How much does it cost with the VAT?

Non-Calculator

- 1) Increase:
 - a) 500 by 10%
 - c) 80 by 15%
 - b) 320 by 10%
 - d) 75 by 20%
 - 2) Decrease:
 - a) 400 by 10%
 - c) 140 by 15%
 - b) 380 by 10%
 - d) 35 by 20%
 - 3) The price of laptop is increased by 15%.
The old price of the laptop was £300.
Work out the new price.
 - 4) The price of a £6800 car is reduced by 10%.
What is the new price?
-

Calculator

- 5) Increase:
 - a) 65 by 12%
 - c) 600 by 17.5%
 - b) 120 by 23%
 - d) 370 by 17.5%
- 6) Decrease:
 - a) 42 by 15%
 - c) 52 by 8.5%
 - b) 79 by 12%
 - d) 8900 by 18%
- 7) The price of a mobile phone is £78.40 plus VAT.
VAT is charged at a rate of 17.5%.
What is the total price of the mobile phone?
- 8) In a sale, normal prices are reduced by 7%.
The normal price of a camera is £89.
Work out the sale price of the camera.
- 9) A car dealer offers a discount of 20% off the normal price of a car, for cash.
Peter intends to buy a car which usually costs £6800.
He intends to pay by cash.
Work out how much he will pay.
- 10) A month ago, John weighed 97.5 kg.
He now weighs 4.5% more.
Work out how much John now weighs.
Give your answer to 1 decimal place.

1. Write the following ratios in their simplest form

a) $6 : 9$

b) $10 : 5$

c) $7 : 21$

d) $4 : 24$

e) $12 : 40$

f) $18 : 27$

g) $4 : 2 : 8$

h) $18 : 63 : 9$

2. Complete the missing value in these equivalent ratios

a) $3 : 5 = 12 : \square$

b) $4 : 9 = \square : 27$

c) $\square : 7 = 16 : 14$

d) $2 : 3 = 3 : \square$

3. Match together cards with equivalent ratios:

$3 : 4$

$10 : 5$

$50 : 100$

$2 : 1$

$5 : 2$

$15 : 20$

$15 : 6$

$1 : 2$

4. The ratio of girls to boys in a class is $4 : 5$.

a) What fraction of the class are girls?

b) What fraction of the class are boys?

5. A model of a plane is made using a scale of $1 : 5$.

a) If the real length of the plane is 20m, what is the length of the model in metres?

b) If the wings of the model are 100cm long, what is the real length of the wings in metres?

6. Share out £250 in the following ratios:

a) $1 : 4$

b) $2 : 3$

c) $7 : 3$

d) $9 : 12 : 4$

7. Share out £80 between Tom and Jerry in the ratio $3 : 2$.

8. A box of chocolates has 3 milk chocolates for every 2 white chocolates.

There are 60 chocolates in the box.

Work out how many white chocolates are in the box.

9. In a bracelet, the ratio of silver beads to gold beads is $5 : 2$.

The bracelet has 25 silver beads.

How many gold beads are in the bracelet?

10. To make mortar you mix 1 shovel of cement with 5 shovels of sand.

How much sand do you need to make 30 shovels of mortar?

- 1) List the first seven prime numbers.
 - 2) Express the following number as the product of their prime factors:
 - a) 30
 - b) 60
 - c) 360
 - d) 220
 - 3) Express the following number as the product of **powers** of their prime factors:
 - a) 24
 - b) 64
 - c) 192
 - d) 175
 - 4) The number 96 can be written as $2^m \times n$, where m and n are prime numbers. Find the value of m and the value of n .
 - 5) The number 75 can be written as $5^x \times y$, where x and y are prime numbers. Find the value of x and the value of y .
-

- 1) Find the Highest Common Factor (HCF) of each of these pairs of numbers.
 - a) 16 and 24
 - b) 21 and 28
 - c) 60 and 150
 - d) 96 and 108
- 2) Find the Least (or Lowest) Common Multiple (LCM) of each of these pairs of numbers.
 - a) 16 and 24
 - b) 21 and 28
 - c) 60 and 150
 - d) 96 and 108
- 3)
 - a) Write 42 and 63 as products of their prime factors.
 - b) Work out the HCF of 42 and 63.
 - c) Work out the LCM of 42 and 63.
- 4)
 - a) Write 240 and 1500 as products of their prime factors.
 - b) Work out the HCF of 240 and 1500.
 - c) Work out the LCM of 240 and 1500.

1) Change the following to normal (or ordinary) numbers.

a) 4.3×10^4

c) 7.03×10^3

e) 1.01×10^4

b) 6.79×10^6

d) 9.2034×10^2

f) 4×10^5

2) Change the following to normal (or ordinary) numbers.

a) 4.3×10^{-4}

c) 7.03×10^{-3}

e) 1.01×10^{-4}

b) 6.79×10^{-6}

d) 9.2034×10^{-2}

f) 4×10^{-5}

3) Change the following to standard form.

a) 360

c) 520 000

e) 1 003

b) 8 900

d) 62 835

f) 6 450 000

4) Change the following to standard form.

a) 0.71

c) 0.00076

e) 0.00009

b) 0.0008

d) 0.0928

f) 0.00000173

5) Work out the following, giving your answer in standard form.

a) $3\,000 \times 5\,000$

d) $5 \times 4 \times 10^3$

g) $7 \times 10^2 \times 3 \times 10^{-4}$

b) 240×0.0002

e) $\frac{8 \times 10^4}{4 \times 10^2}$

h) $2 \times 3.6 \times 10^{-5}$

c) $9 \times 1.1 \times 10^7$

f) $9 \times 10^2 \times 2 \times 10^{-5}$

i) $6 \times 4.1 \times 10^3$

Recurring Decimals into Fractions

- 1) Write each recurring decimal as an exact fraction, in its lowest terms.

a) $0.\dot{5}$

b) $0.\dot{7}$

c) $0.\dot{4}$

d) $0.\dot{2}\dot{4}$

e) $0.\dot{7}\dot{5}$

f) $0.\dot{8}\dot{2}$

g) $0.\dot{6}\dot{1}\dot{7}$

h) $0.\dot{2}\dot{1}\dot{6}$

i) $0.\dot{7}\dot{1}\dot{4}$

j) $0.\dot{3}\dot{2}\dot{4}$

k) $0.\dot{7}235\dot{7}$

l) $0.\dot{6}521\dot{4}$

Four Rules of Negatives

Work out the following without a calculator

a) $6 - 9 =$

b) $4 \times -3 =$

c) $-10 \div -5 =$

d) $-7 - -6 =$

e) $25 \div -5 =$

f) $-2 + -6 =$

g) $7 - -3 =$

h) $6 \times -9 =$

i) $5 + -11 =$

j) $-8 \times 4 =$

k) $12 + -3 =$

l) $5 + 9 - 3 =$

m) $-3 \times -2 \times 4 =$

n) $-6 - -5 - 8 =$

o) $-5 \times -6 \times -2 =$

p) $8 \div -4 \times -5 =$

q) $2 + -8 + -7 =$

r) $13 + -13 =$

s) $16 \div -2 \times 4 =$

t) $11 - 3 + -9 - -5 =$

u) $-7 \times -2 \times -3 =$

v) $-1 + -3 + 2 =$

Division by Two-Digit Decimals

1) Work out the following without a calculator

a) $350 \div 0.2$

b) $2 \div 0.25$

c) $0.45 \div 0.9$

d) $2.42 \div 0.4$

e) $30.66 \div 2.1$

f) $5.886 \div 0.9$

g) $38.08 \div 1.7$

h) $98.8 \div 0.08$

2) Sam is filling a jug that can hold 1.575 litres, using a small glass.

The small glass holds 0.035 litres.

How many of the small glasses will he need?

1. Work out an estimate for the value of

a)
$$\frac{547}{4.8 \times 9.7}$$

b)
$$\frac{69 \times 398}{207}$$

c)
$$\frac{7.5 \times 2.79}{2.71 + 3.19}$$

d)
$$\frac{409 \times 5.814}{0.19}$$

2. a) Work out an estimate for

$$\frac{19.6 \times 31.7}{7.9 \times 5.2}$$

b) Use your answer to part (a) to find an estimate for

$$\frac{196 \times 317}{79 \times 52}$$

3. a) Work out an estimate for

$$\frac{6.13 \times 9.68}{3.79 \times 2.56}$$

b) Use your answer to part (a) to find an estimate for

$$\frac{613 \times 968}{379 \times 256}$$

Algebraic Simplification

1) Simplify

- a) $x + x$
- b) $x \times x$
- c) $3x + 2x$
- d) $3x \times 2x$
- e) $2x^2y^3 + 4x^2y^3$
- f) $2x^2y \times 3xy^3$

2) Simplify

- a) $x + y + x + y$
- b) $3x + 2y + x + 5y$
- c) $6y + 2x - 2y - 3x$
- d) $5p - 3q + p + 2q$

3) Expand and simplify

- a) $2(x + y) + 3(x + y)$
- b) $3(2x + y) + 2(5x + 3y)$
- c) $5(x + y) + 3(2x - y)$
- d) $3(2c + d) - 2(c + d)$
- e) $4(2p + q) - 3(2p - q)$
- f) $3(4x - 2y) + 2(x + 2y)$
- g) $6(x - 3y) - 2(2x - 5y)$

4) Expand and simplify

- a) $5(3p + 2) - 2(4p - 3)$
- b) $4(2x + 3) - (x - 2)$

5) a) Simplify $pq + 2pq$ b) Simplify $5x + 3y - x - 4y$ 6) a) Simplify $6a + 5b - 3b + a$ b) Simplify $x^4 + x^4$ 7) a) Simplify $x + y + x + y + x$ b) Simplify $t^2 + t^2 + t^2$ 8) a) Simplify $a^3 \times a^3$ b) Simplify $3x^2y \times 4xy^3$ 9) a) Simplify $3d + e - d + 4e$ b) Simplify $3x^2 - x^2$ c) Simplify $5t + 8d - 2t - 3d$ d) Simplify $4t \times 2q$

10) The table shows some expressions.

$2(p + p)$	$2p \times p$	$3p + 2p$	$2 + 2p$	$2p + 2p$

Two of the expressions **always** have the same value as $4p$.
Tick the boxes underneath the **two** expressions.

11) Expand and simplify

(i) $4(x + 5) + 3(x - 6)$ (ii) $3(2x - 1) - 2(x - 4)$ (iii) $5(2y + 2) - (y + 3)$

- 1) Expand these brackets
 - a) $2(x + 3)$
 - b) $3(2x + 4)$
 - c) $5(3p - 2q)$
 - d) $4(x^2 + 2y^2)$
 - e) $r(r - r^2)$

- 2) Expand and simplify
 - a) $(x + 1)(x + 2)$
 - b) $(x + 3)(2x + 4)$
 - c) $(2x + 1)(3x + 2)$

- 3) Expand and simplify
 - a) $(x + 3)(x - 2)$
 - b) $(x - 1)(x + 4)$
 - c) $(x - 3)(x - 2)$

- 4) Expand and simplify
 - a) $(2p + 3)(p - 2)$
 - b) $(3t - 2)(2t + 3)$
 - c) $(2x - 5)(3x - 2)$

- 5) Expand and simplify
 - a) $(x + 3y)(x + 4y)$
 - b) $(2p + q)(3p + 2q)$

- 6) Expand and simplify
 - a) $(2x + 1)^2$
 - b) $(3x - 2)^2$
 - c) $(2p + q)^2$

1) Factorise

a) $2x + 4$

b) $2y + 10$

c) $3x + 12$

d) $3x - 6$

e) $5x - 15$

2) Factorise

a) $p^2 + 7p$

b) $x^2 + 4x$

c) $y^2 - 2y$

d) $p^2 - 5p$

e) $x^2 + x$

3) Factorise

a) $2x^2 + 6x$

b) $2y^2 - 8y$

c) $5p^2 + 10p$

d) $7c^2 - 21c$

e) $6x^2 + 9x$

4) Factorise

a) $2x^2 - 4xy$

b) $2t^2 + 10tu$

c) $6x^2 - 8xy$

d) $3x^2y^2 + 9xy$

Solve the following equations

1) $2p - 1 = 13$

2) $4y + 1 = 21$

3) $6x - 7 = 32$

4) $x + x + x + x = 20$

5) $x + 3x = 40$

6) $5(t - 1) = 20$

7) $4(5y - 2) = 52$

8) $4(y + 3) = 24$

9) $20x - 15 = 18x - 7$

10) $4y + 3 = 2y + 10$

11) $2x + 17 = 5x - 4$

12) $2x + 7 = 16 - 4x$

13) $5(x + 3) = 2(x + 6)$

14) $4(2y + 1) = 2(12 - y)$

15) $7 - 3x = 2(x + 1)$

16) $\frac{x - 3}{2} = 5$

17) $\frac{2x + 4}{3} = 7$

18) $\frac{40 - x}{3} = 4 + x$

- 1) The width of a rectangle is x centimetres.
The length of the rectangle is $(x + 5)$ centimetres.

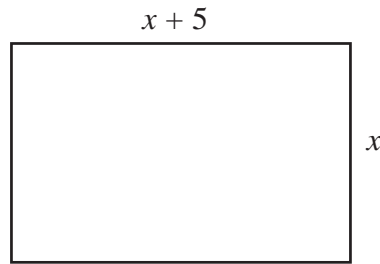

- a) Find an expression, in terms of x , for the perimeter of the rectangle.
Give your answer in its simplest form.

The perimeter of the rectangle is 38 centimetres.

- b) Work out the length of the rectangle.

2)

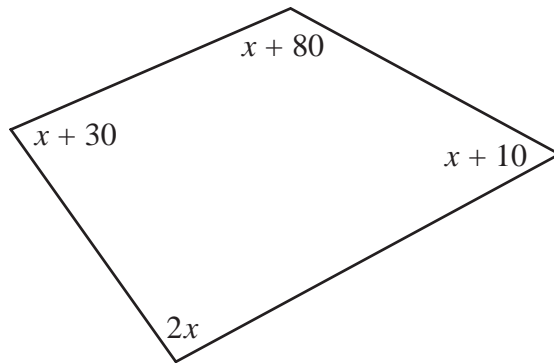

*Diagram NOT
accurately drawn*

The sizes of the angles, in degrees, of the quadrilateral are

$x + 10$
 $2x$
 $x + 80$
 $x + 30$

- a) Use this information to write down an equation in terms of x .
- b) Use your answer to part (a) to work out the size of the smallest angle of the quadrilateral.
- 3) Sarah buys 6 cups and 6 mugs
A cup costs $\pounds x$
A mug costs $\pounds(x + 3)$
- a) Write down an expression, in terms of x , for the total cost, in pounds, of 6 cups and 6 mugs.
- b) If the total cost of 6 cups and 6 mugs is $\pounds 48$, write an equation in terms of x .
- c) Solve your equation to find the cost of a cup and the cost of a mug.

- 1) Make c the subject of the formula.

$$a = b + cd$$

- 2) Make t the subject of the formula.

$$u = v + 2t$$

- 3) Make n the subject of the formula.

$$M = 3n + 5$$

- 4) Make z the subject of the formula.

$$x = 3y + z$$

- 5) $r = 5s + 3t$

a) Make t the subject of the formula.

b) Make s the subject of the formula.

- 6) Rearrange $y = 3x + 1$ to make x the subject.

- 7) Rearrange $y = \frac{1}{2}x + 2$ to make x the subject.

- 8) Rearrange $y = \frac{1}{3}x + 1$ to make x the subject.

- 1) Represent this inequality on the number line

$$-3 < x \leq 2$$

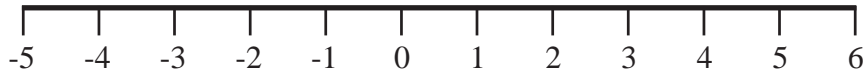

- 2) Represent this inequality on the number line

$$-1 < x < 5$$

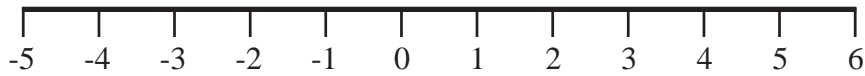

- 3) Write down the inequality shown

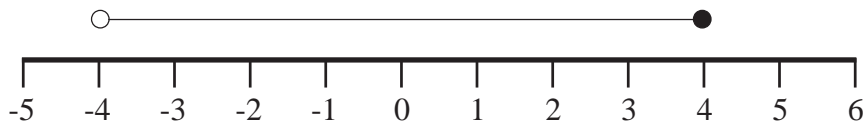

- 4) Write down the inequality shown

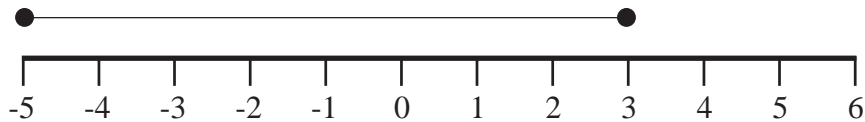

- 5) If y is an integer, write down all the possible values of

$$-2 < y < 5$$

- 6) If x is an integer, write down all the possible values of

$$-9 < x < -5$$

1) Solve

a) $3x - 1 > 5$

b) $7y + 2 \leq 30$

c) $\frac{x}{2} - 3 \geq 2$

d) $5 + 2x > 7$

e) $8 < 5p - 2$

f) $\frac{y}{3} + 5 \geq 3$

g) $\frac{2x}{3} - 5 \geq -3$

h) $6x - 5 > 2x + 3$

i) $3p - 9 < 6 - 2p$

j) $5 - 3y < 2y - 10$

2) a) Solve the inequality

$$2z + 2 \geq 7$$

b) Write down the smallest **integer** value of z which satisfies the inequality

$$2z + 2 \geq 7$$

3) $5x + 2y < 10$

x and y are both integers.

Write down two possible pairs of values that satisfy this inequality.

$x = \dots\dots\dots, y = \dots\dots\dots$

and

$x = \dots\dots\dots, y = \dots\dots\dots$

- 1) The equation

$$x^3 - x = 29$$

has a solution between 3 and 4

Use a trial and improvement method to find this solution.

Give your answer correct to 1 decimal place.

You must show **all** your working.

- 2) The equation

$$x^3 - 4x = 25$$

has a solution between 3 and 4

Use a trial and improvement method to find this solution.

Give your answer correct to 1 decimal place.

You must show **all** your working.

- 3) The equation

$$x^3 - 2x = 68$$

has a solution between 4 and 5

Use a trial and improvement method to find this solution.

Give your answer correct to 1 decimal place.

You must show **all** your working.

- 4) The equation

$$x^3 + 4x = 101$$

has one solution which is a positive number.

Use a trial and improvement method to find this solution.

Give your answer correct to 1 decimal place.

You must show **all** your working.

1) Write as a power of 8

a) $8^4 \times 8^3$

b) $8^{12} \div 8^7$

2) Write as a power of 3

a) $3^2 \times 3^9$

b) $3^{10} \div 3^3$

3) Simplify

a) $k^5 \times k^2$

b) $x^4 \div x^2$

c) $\frac{k^{11}}{k^6}$

d) $(k^8)^2$

4) Simplify

eg. $(2xy^3)^4 = 2xy^3 \times 2xy^3 \times 2xy^3 \times 2xy^3 = 16x^4y^{12}$

a) $(2xy^5)^3$

b) $(2x^2y^2)^3$

c) $(4xy^4)^2$

d) $(3xy^2)^4$

5) $2^x \times 2^y = 2^{10}$

and

$2^x \div 2^y = 2^2$

Work out the value of x and the value of y .

6) $5^x \times 5^y = 5^{12}$

and

$5^x \div 5^y = 5^6$

Work out the value of x and the value of y .

7) $a = 2^x$, $b = 2^y$

Express in terms of a and b

a) 2^{x+y}

b) 2^{2x}

c) 2^{3y}

d) 2^{x+2y}

1. Write down the first 5 terms and the 10th term of the following sequences:

eg. $2n + 1$ 3, 5, 7, 9, 11.....21

a) $2n + 2$

d) $7n$

b) $3n + 1$

e) $3n - 1$

c) $n + 3$

f) $7n - 3$

2. Find the n^{th} term of the following sequences:

a) 5, 10, 15, 20...

d) 22, 18, 14, 10...

b) 5, 8, 11, 14...

e) -3, 3, 9, 15...

c) 1, 8, 15, 22...

f) 4, -1, -6, -11...

3. Here are some patterns made from sticks.



Pattern 1

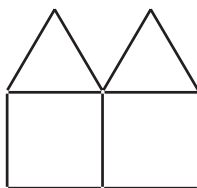

Pattern 2

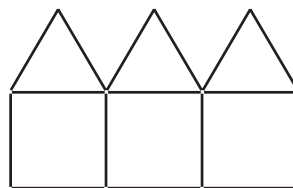

Pattern 3

a) Draw pattern 4 in the space, below..

b) How many sticks are used in

(i) pattern 10

(ii) pattern 20

(iii) pattern 50

c) Find an expression, in terms of n , for the number of sticks in pattern number n .

d) Which pattern number can be made using 301 sticks?

Drawing Straight Line Graphs

1) a) Complete the table of values for $y = 2x - 3$

x	-1	0	1	2	3	4
y				1		

b) Using the axes on the right draw the graph of $y = 2x - 3$

c) Use your graph to work out the value of y when $x = 2.5$

d) Use your graph to work out the value of x when $y = 4.5$

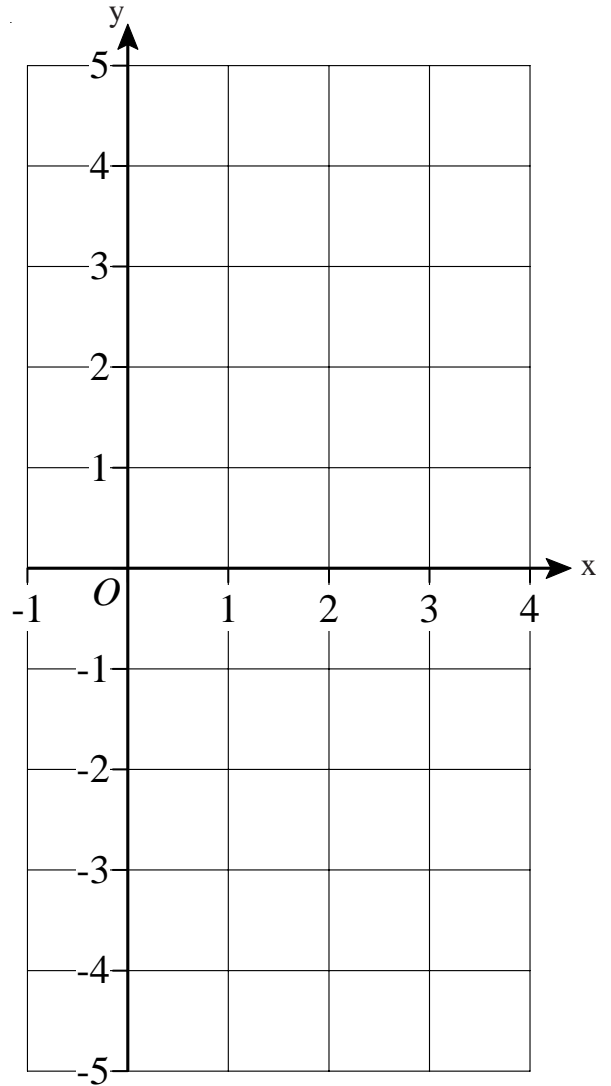

2) a) Complete the table of values for $y = 2 - x$

x	-1	0	1	2	3	4
y					-1	

b) Using the axes on the right, again, draw the graph of $y = 2 - x$

3) a) Complete the table of values for $y = \frac{1}{2}x - 1$

x	-1	0	1	2	3	4
y				0		

b) Draw the graph of $y = \frac{1}{2}x - 1$

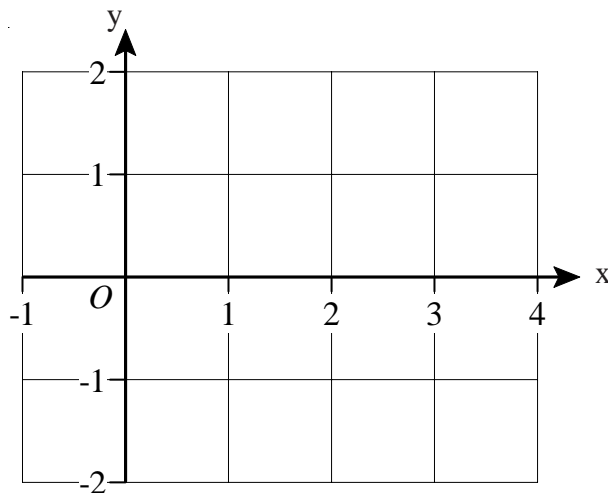

c) Use your graph to find the value of y when $x = 3.5$

Finding the Equation of a Straight Line

1) Find the equations of lines A, B and C on the axes below

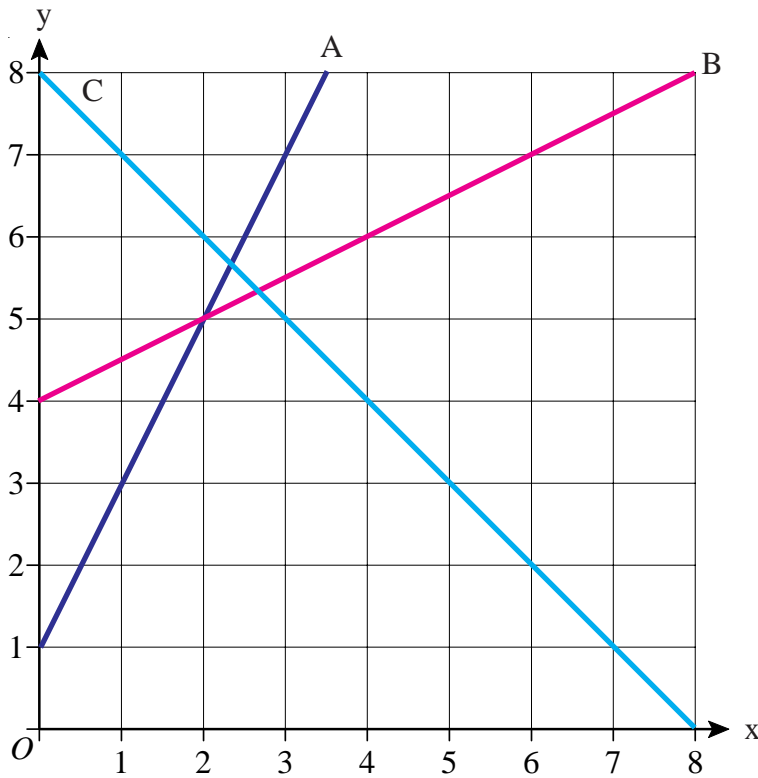

2) Find the equations of lines A, B and C on the axes below

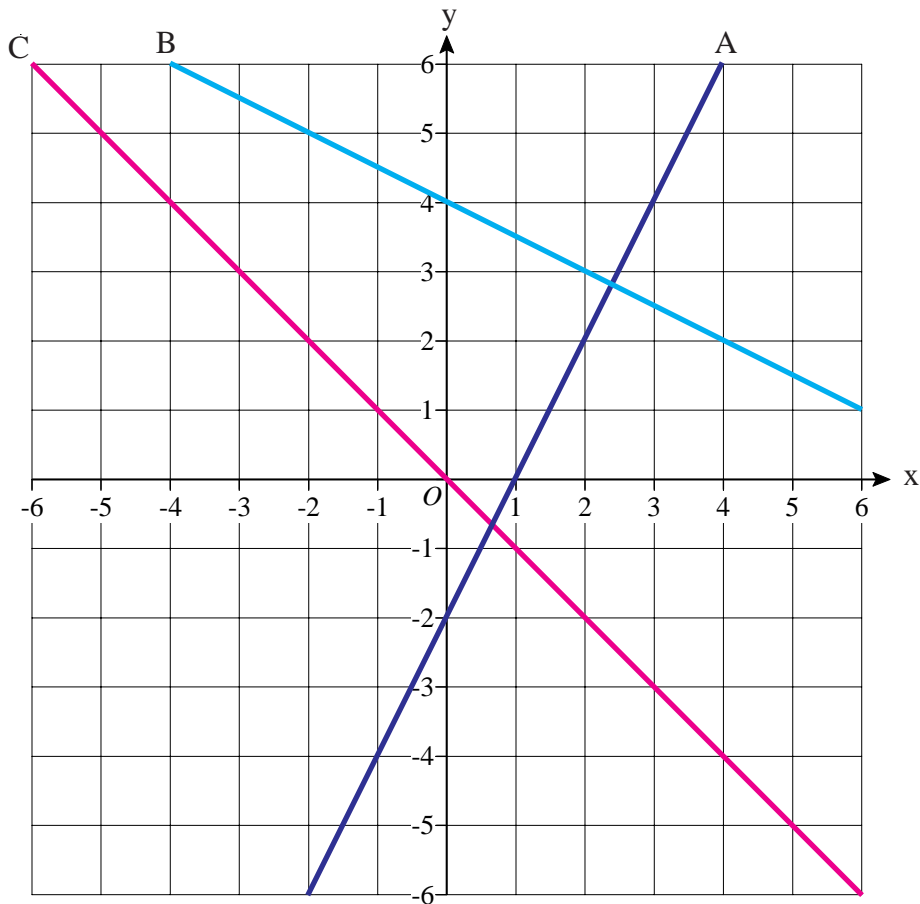

Solving Simultaneous Equations Graphically

- 1) On the axes below, the graphs of $y = x + 2$ and $y = 6 - x$ have been drawn.
Use the graphs to solve the simultaneous equations $y = x + 2$ and $y = 6 - x$

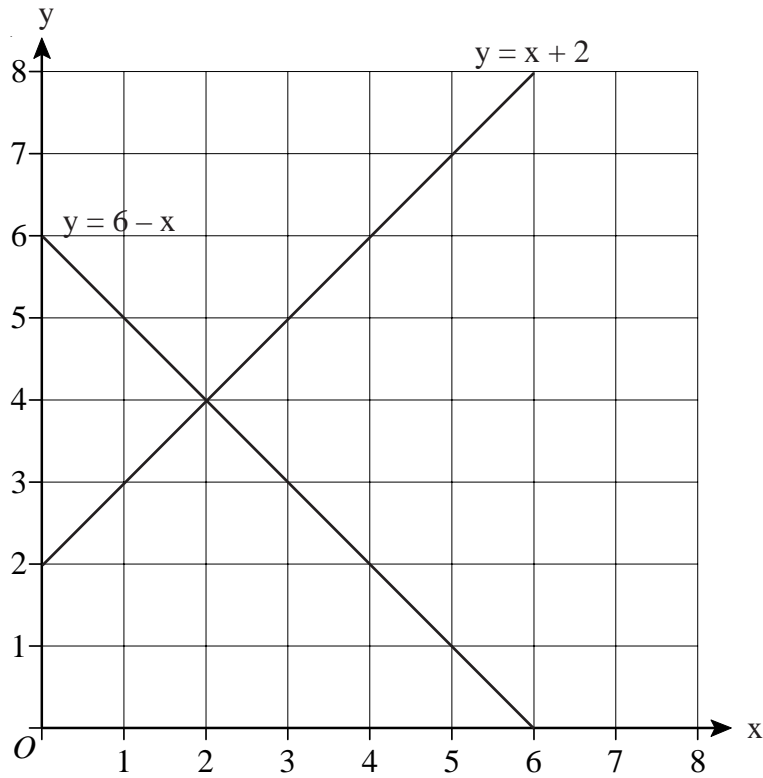

- 2) On the axes below draw the graphs of $y = 2x + 1$ and $y = 7 - x$
Use your graphs to solve the simultaneous equations $y = 2x + 1$ and $y = 7 - x$

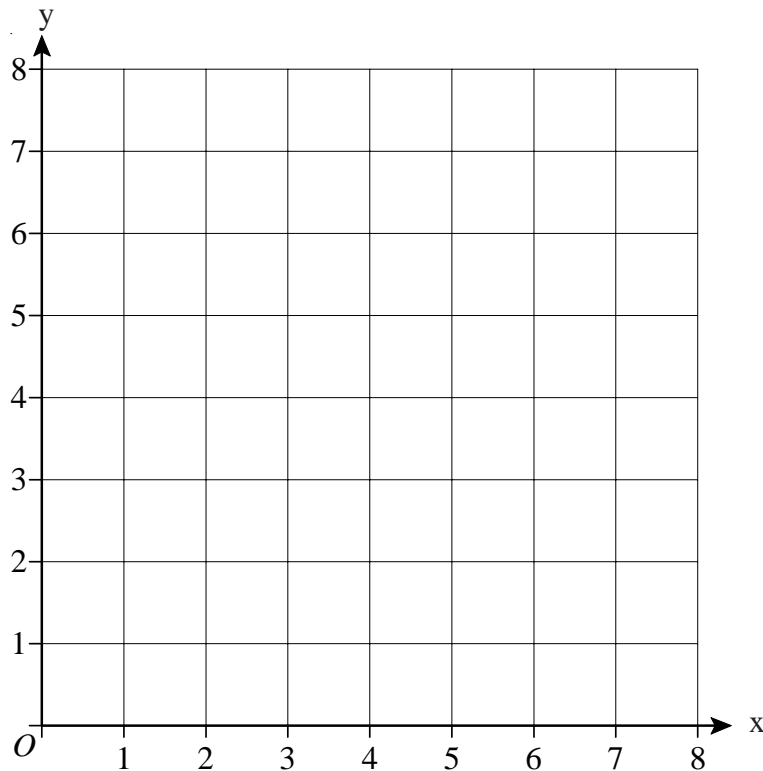

Drawing Quadratic Graphs

- 1) a) Complete the table of values for $y = 2x^2 - 3x$

x	-2	-1	0	1	2	3
y	14		0			9

- b) On the grid, draw the graph of $y = 2x^2 - 3x$ for values of x from -2 to 3

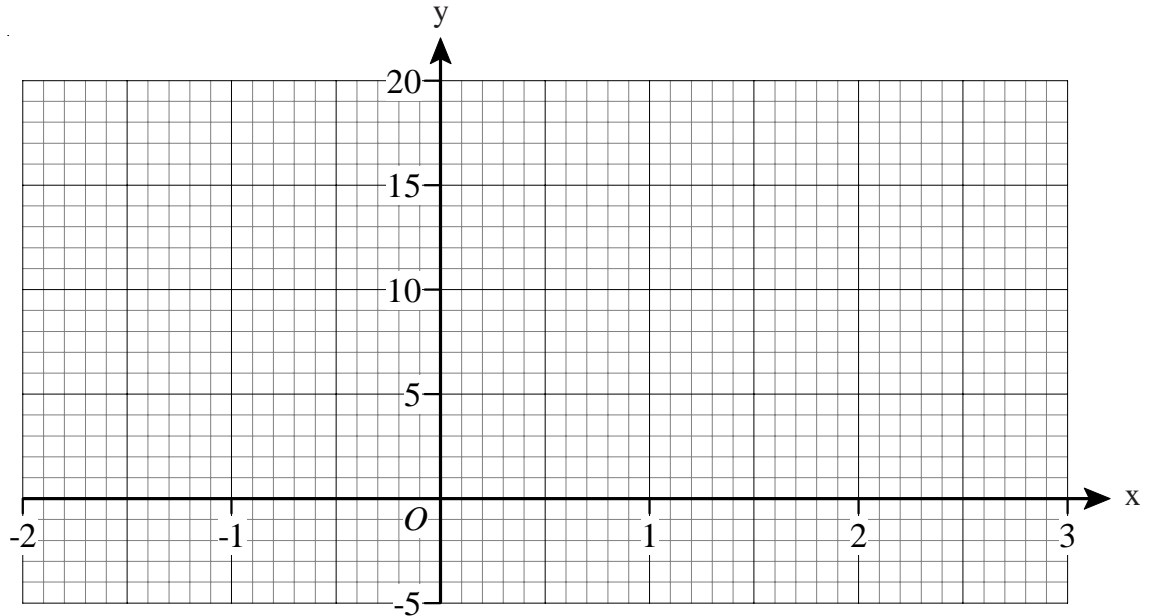

- c) Use the graph to find the value of y when $x = -1.5$
 d) Use the graph to find the values of x when $y = 4$

- 2) a) Complete the table of values for $y = x^2 - 2x$

x	-2	-1	0	1	2	3
y	8		0			

- b) On the grid, draw the graph of $y = x^2 - 2x$ for values of x from -2 to 3

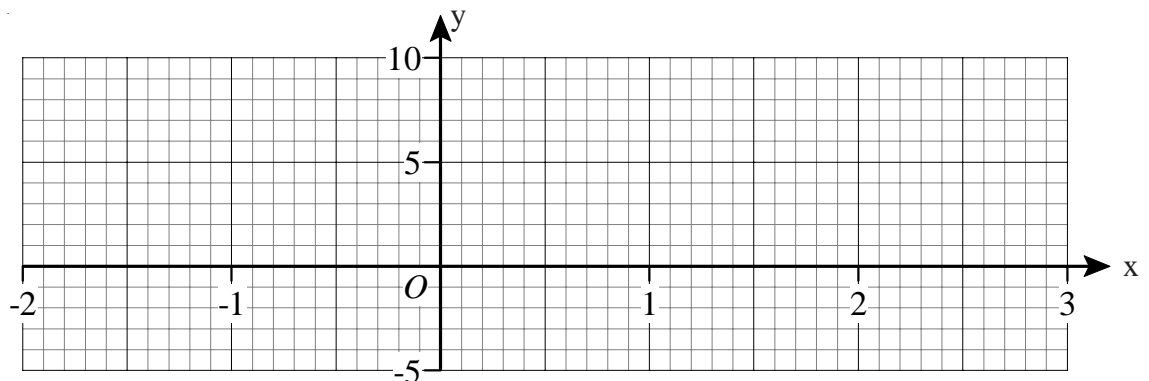

- c) (i) On the same axes draw the straight line $y = 2.5$
 (ii) Write down the values of x for which $x^2 - 2x = 2.5$

- 1) Sarah travelled 20 km from home to her friend's house. She stayed at her friend's house for some time before returning home. Here is the travel graph for part of Sarah's journey.

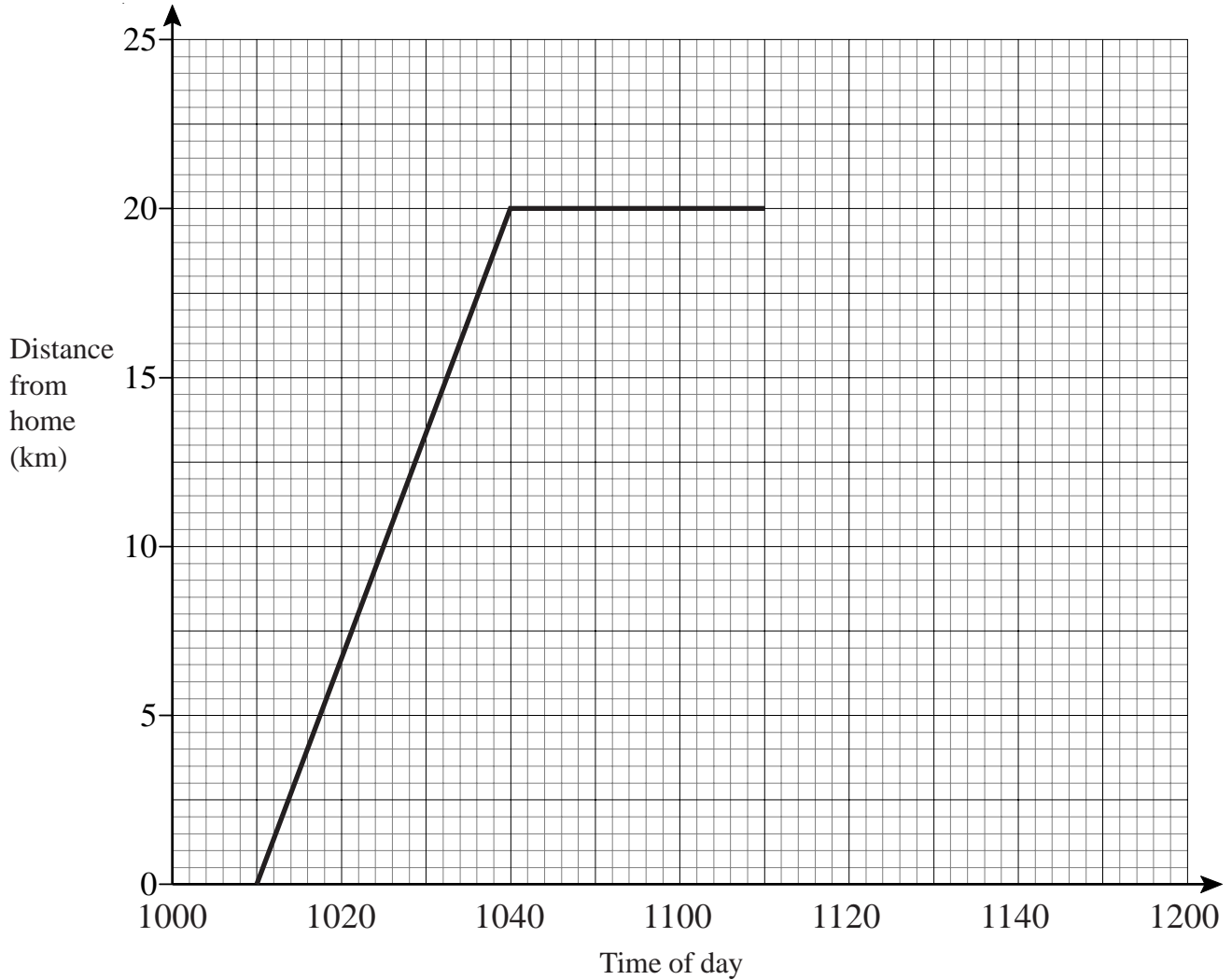

a) At what time did Sarah leave home?

b) How far was Sarah from home at 1030?

Sarah left her friend's house at 1110 to return home.

c) Work out the time in minutes Sarah spent at her friend's house.

Sarah returned home at a steady speed.

She arrived home at 1150

d) Complete the travel graph.

e) Work out Sarah's average speed on her journey from her home to her friend's house. Give your answer in kilometres per hour.

f) Work out Sarah's average speed on her journey home from her friend's house. Give your answer in kilometres per hour.

Pythagoras' Theorem

- 1) Find the length of side AC.
Give your answer to 1 decimal place.

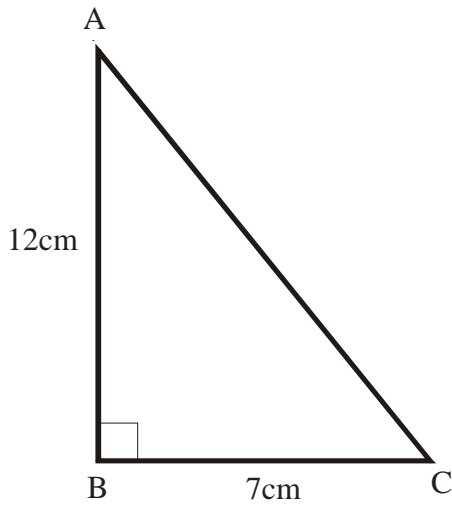

- 2) Find the length of side QR.
Give your answer to 1 decimal place.

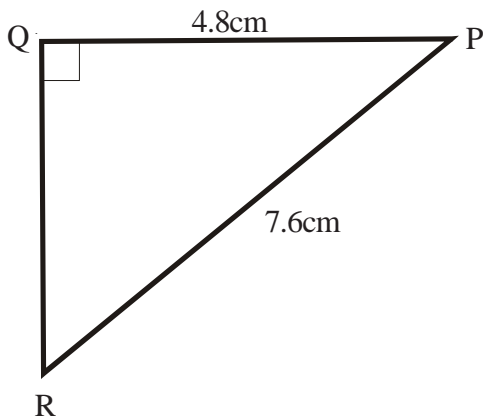

- 3) Find the length of side SU.
Give your answer to 1 decimal place.

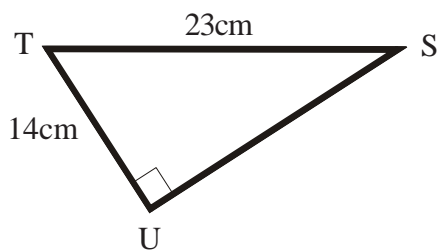

- 4) Below is a picture of a doorway.
Find the size of the diagonal of the doorway.
Give your answer to 1 decimal place.

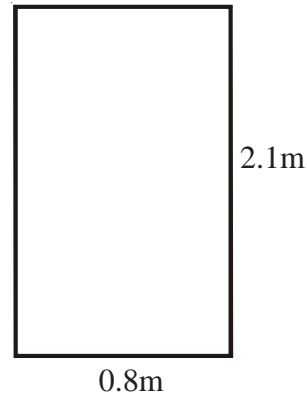

- 5) In the sketch of the rectangular field, below, James wants to walk from B to D.

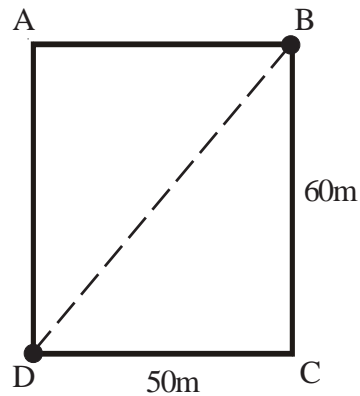

Which of the following routes is shorter and by how much?
From B to C to D or straight across the field from B to D.
Give your answer to the nearest metre.

- 6) Fiona keeps her pencils in a cylindrical beaker as shown below.
The beaker has a diameter of 8cm and a height of 17cm.
Will a pencil of length 19cm fit in the beaker without poking out of the top?
All workings must be shown.

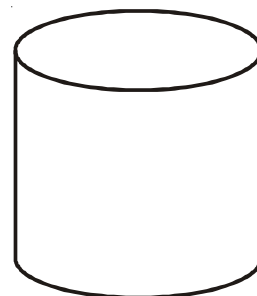

Pythagoras - Line on a Graph

- 1) Points P and Q have coordinates (1, 4) and (5, 2).
 Calculate the shortest distance between P and Q.
 Give your answer correct to 1 decimal place.

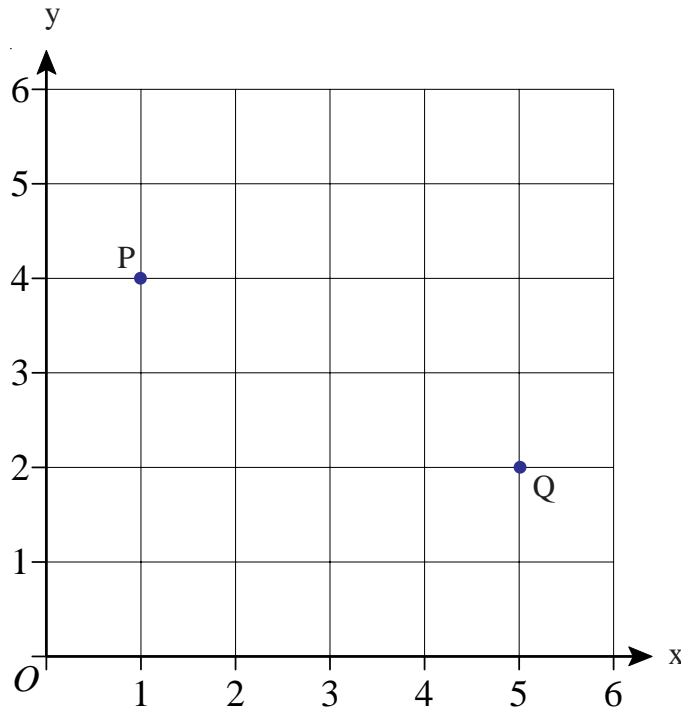

- 2) Points A and B have coordinates (-4, 3) and (3, -2).
 Calculate the shortest distance between A and B.
 Give your answer correct to 1 decimal place.

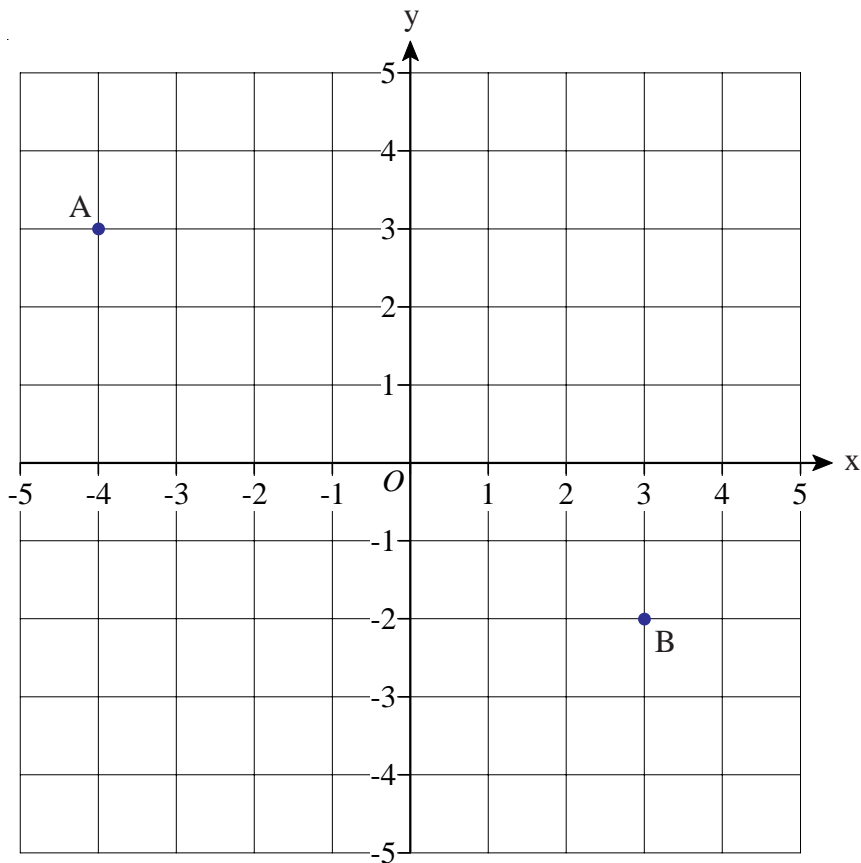

- 1) A cuboid lies on the coordinate axes.

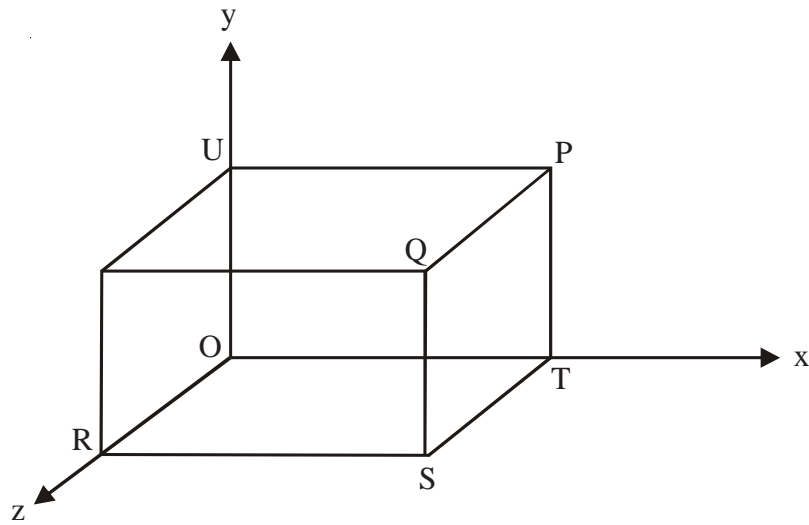

The point Q has coordinates $(5, 3, 4)$

- Write down the coordinates of the point P
- Write down the coordinates of the point T
- Write down the coordinates of the point S
- Write down the coordinates of the point R
- Write down the coordinates of the point U

- 2) A cuboid lies on the coordinate axes.

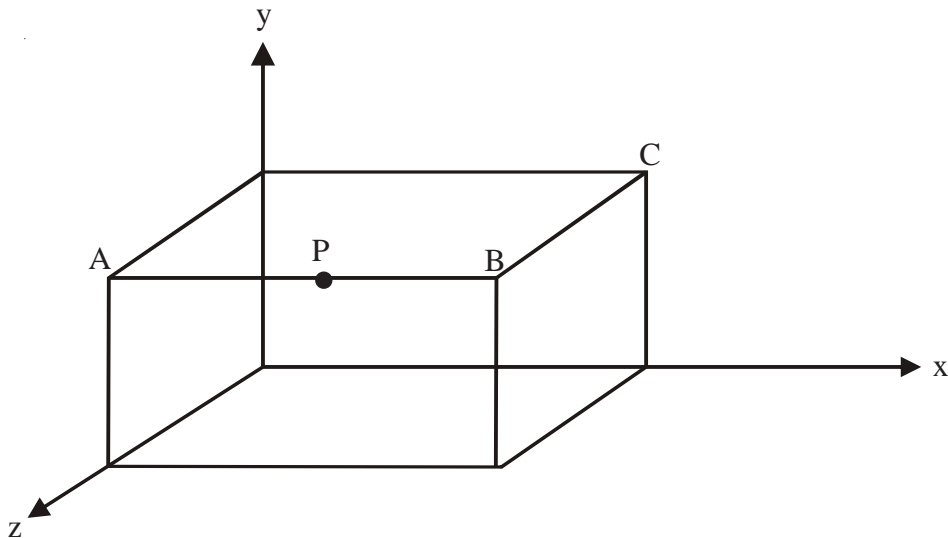

Point P lies half way between A and B and has coordinates $(3, 4, 5)$

- Write down the coordinates of B.
- Write down the coordinates of C.

Surface Area of Cuboids

- 1) Find the surface area of this cube and cuboid.

Cube

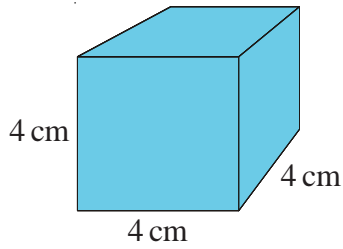

Cuboid

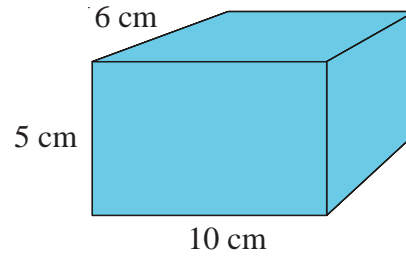

- 2) Find the surface area of this cuboid.

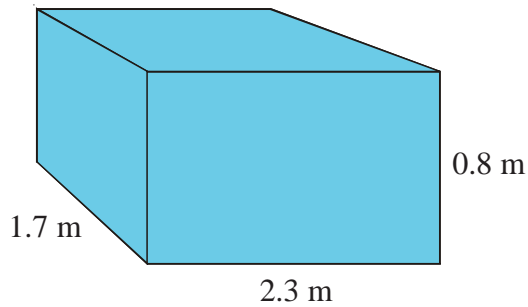

- 3) A water tank measures 2 m by 3 m by 4 m. It has no top. The outside of the tank, including the base, has to be painted. Calculate the surface area which will be painted.

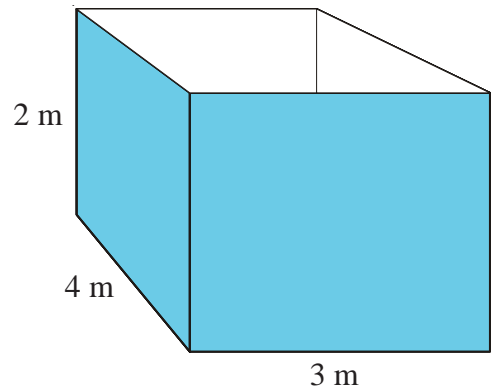

- 4) A water tank measures 2 m by 5 m by 6 m. It has no top. The outside of the tank, including the base, has to be painted. A litre of paint will cover an area of 4.3 m^2 . Paint is sold in 5 litre tins and each tin costs £13.50. How much will it cost to paint the tank? You must show all your working.

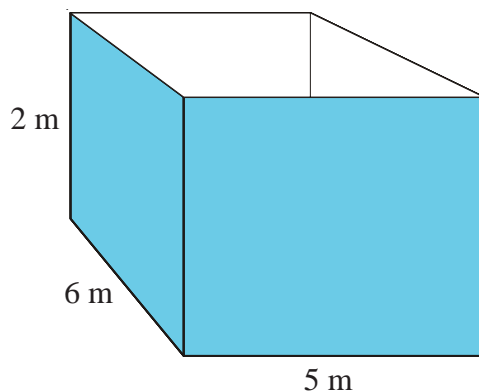

Volume of a Prism

- 1) The diagram shows a cuboid.

Work out the volume of the cuboid.

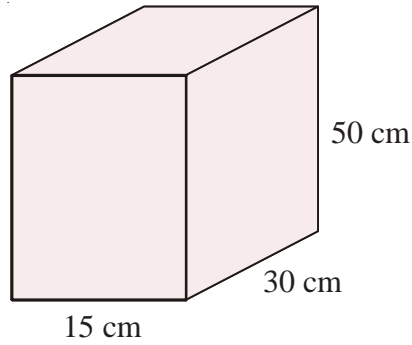

- 2) Calculate the volume of this triangular prism.

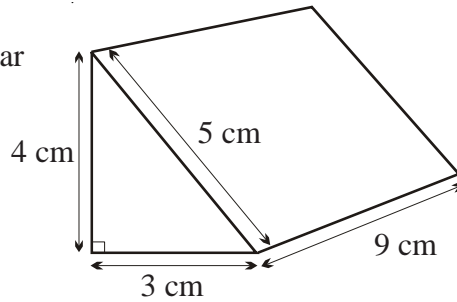

- 3) An ice hockey puck is in the shape of a cylinder with a radius of 3.8 cm and a thickness of 2.5 cm.

Take π to be 3.14

Work out the volume of the puck.

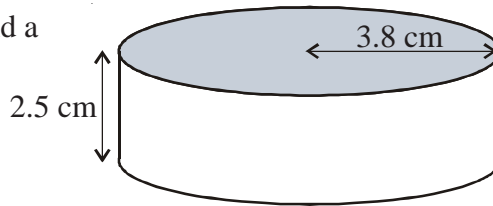

- 4) A cuboid has: a volume of 80cm^3
a length of 5 cm
a width of 2 cm

Work out the height of the cuboid.

- 5) Work out the maximum number of boxes which can fit in the carton.

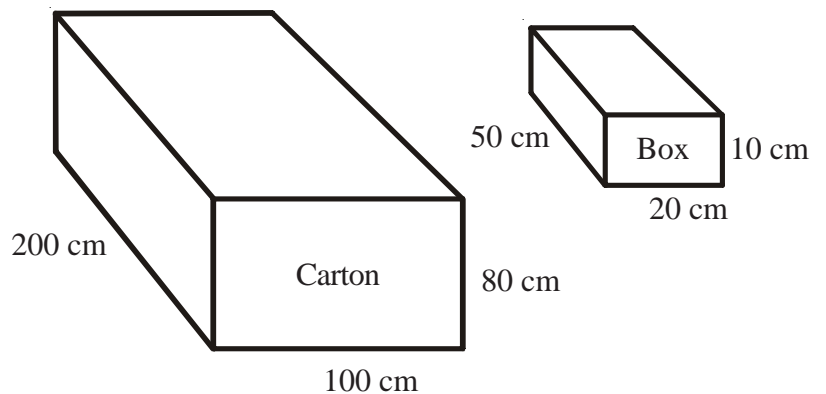

Similar Shapes

- 1) The diagram shows two quadrilaterals that are mathematically **similar**.

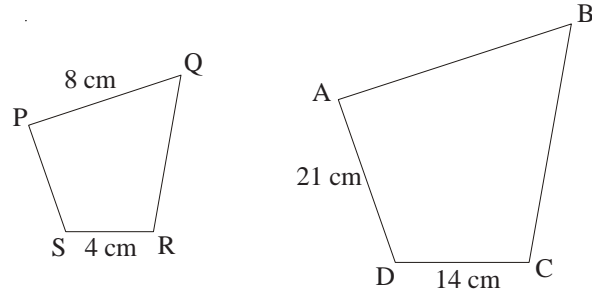

- Calculate the length of AB
- Calculate the length of PS

- 2) SV is parallel to TU.
 RST and RVU are straight lines.
 RS = 9 cm, ST = 3 cm, TU = 7 cm, RV = 6 cm

Calculate the length of VU.

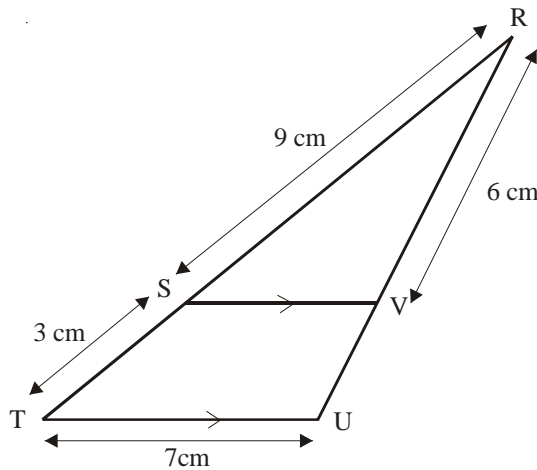

- 3) BE is parallel to CD.
 ABC and AED are straight lines.
 AB = 4 cm, BC = 6 cm, BE = 5 cm, AE = 4.4 cm

- Calculate the length of CD.
- Calculate the length of ED.

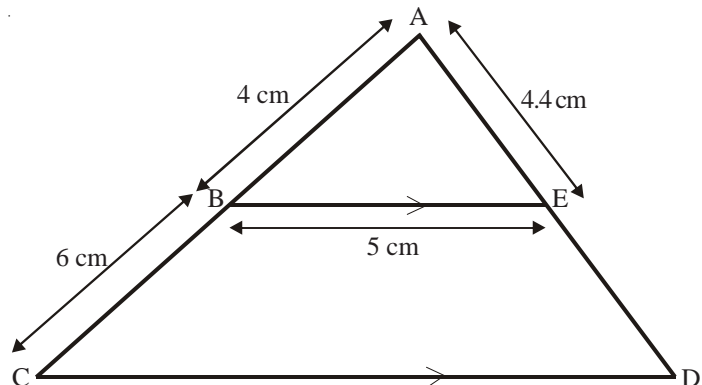

- 1) The table shows some expressions.
The letters a, b, c and d represent lengths.
 π and 3 are numbers that have no dimensions.

Underneath each one write

L if it is a length

A if it is an area

V if it is a volume

N if it is none of the above.

$\frac{\pi abc}{3d}$	πa^3	$3a^2$	$\pi a^2 + b$	$\pi(a + b)$	$3(c^2 + d^2)$	$3ad^2$

- 2) The table shows some expressions.
The letters a, b, c and d represent lengths.
 π and 2 are numbers that have no dimensions.

Underneath each one write

L if it is a length

A if it is an area

V if it is a volume

N if it is none of the above.

$2a^2$	$\frac{\pi ab^3}{2d}$	πbc	$ac + bd$	$\pi d(a + b)$	$2(c + d)^3$	$2\pi bc^2$

1. A silver necklace has a mass of 123 grams, correct to the nearest gram.
 - a) Write down the least possible mass of the necklace.

 - b) Write down the greatest possible mass of the necklace.

2. Each of these measurements was made correct to one decimal place.
Write the maximum and minimum possible measurement in each case.
 - a) 4.6 cm
 - b) 0.8 kg
 - c) 12.5 litres
 - d) 25.0 km/h

 - e) 10.3 s
 - f) 36.1 m
 - g) 136.7 m/s
 - h) 0.1 g

3. Each side of a regular octagon has a length of 20.6 cm, correct to the nearest millimetre.
 - a) Write down the least possible length of each side.

 - b) Write down the greatest possible length of each side.

 - c) Write down the greatest possible perimeter of the octagon.

4. A girl has a pencil that is of length 12 cm, measured to the nearest centimetre.
Her pencil case has a diagonal of length 12.3 cm, measured to the nearest millimetre.
Explain why it might not be possible for her to fit the pen in the pencil case.

5. A square has sides of length 7 cm, correct to the nearest centimetre.
 - a) Calculate the lower bound for the perimeter of the square.

 - b) Calculate the upper bound for the area of the square.

- 1) Jane runs 200 metres in 21.4 seconds.
Work out Jane's average speed in metres per second.
Give your answer correct to 1 decimal place.

 - 2) A car travels at a steady speed and takes five hours to travel 310 miles.
Work out the average speed of the car in miles per hour.

 - 3) A plane flies 1440 miles at a speed of 240 mph.
How long does it take?

 - 4) A marathon runner runs at 7.6 mph for three and a half hours.
How many miles has he run?

 - 5) A car takes 15 minutes to travel 24 miles.
Find its speed in **mph**.

 - 6) A cyclist takes 10 minutes to travel 2.4 miles.
Calculate the average speed in mph.
-
- 7) An ice hockey puck has a volume of 113 cm^3 .
It is made out of rubber with a density of $1.5 \text{ grams per cm}^3$.
Work out the mass of the ice hockey puck.

 - 8) An apple has a mass of 160 g and a volume of 100 cm^3 .
Find its density in g/cm^3 .

 - 9) A steel ball has a volume of 1500 cm^3 .
The density of the ball is 95 g/cm^3 .
Find the mass of the ball in kg.

 - 10) The mass of a bar of chocolate is 1800 g.
The density of the chocolate is 9 g/cm^3 .
What is the volume of the bar of chocolate?

Bisecting a Line

- 1) Using ruler and compasses, bisect line AB.

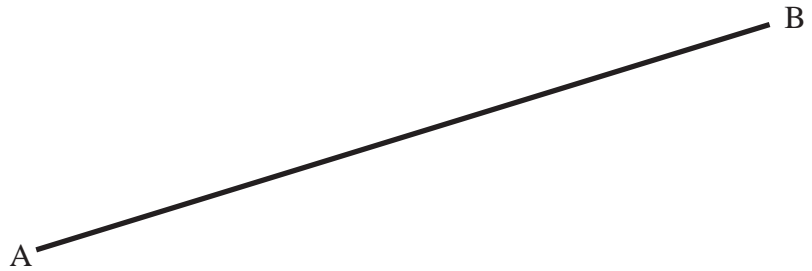

- 2) Using ruler and compasses
- a) Bisect line AB
 - b) Bisect line BC
 - c) Bisect line AC
 - d) Place your compass point where your three lines cross*

Now open them out until your pencil is touching vertex A.
Draw a circle using this radius.

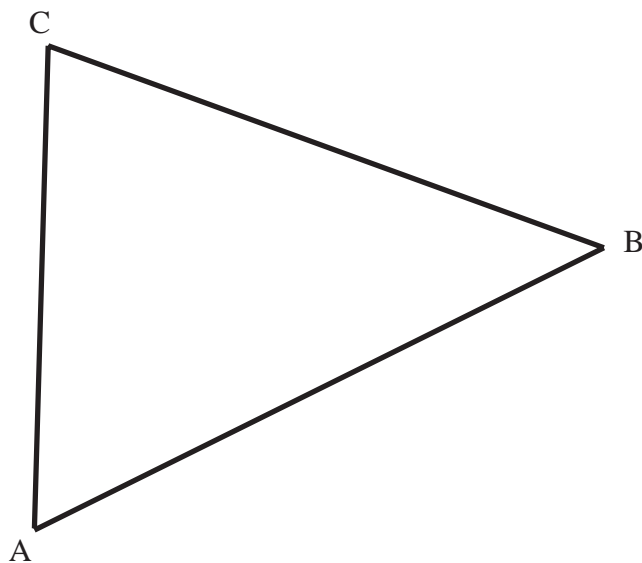

* If your three lines don't cross at a point then you have a mistake somewhere or just haven't been accurate enough.

Drawing a Perpendicular to a Line

- 1) Use ruler and compasses to **construct** the perpendicular to the line segment AB that passes through the point P.
You must show all construction lines.

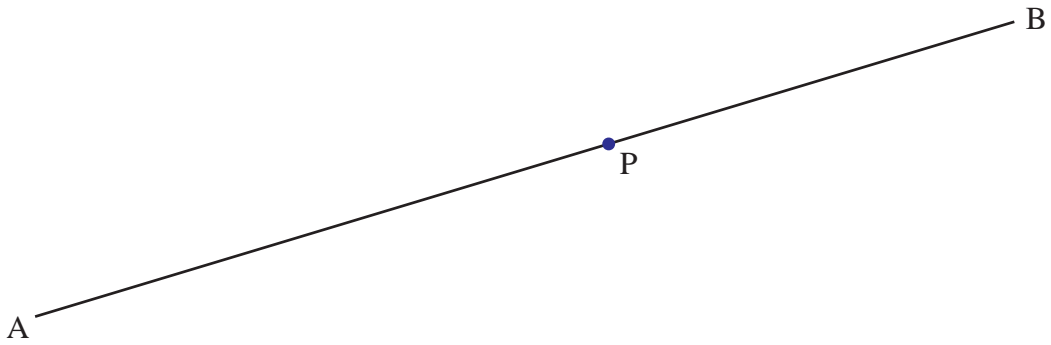

- 2) Use ruler and compasses to **construct** the perpendicular to the line segment CD that passes through the point P.
You must show all construction lines.

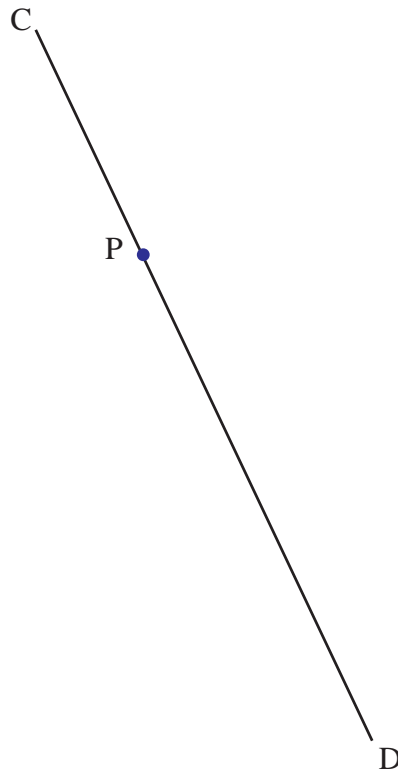

Bisecting an Angle

- 1) Using ruler and compasses, bisect angle ABC.



- 2) The diagram below shows the plan of a park.
The border of the park is shown by the quadrilateral RSUV

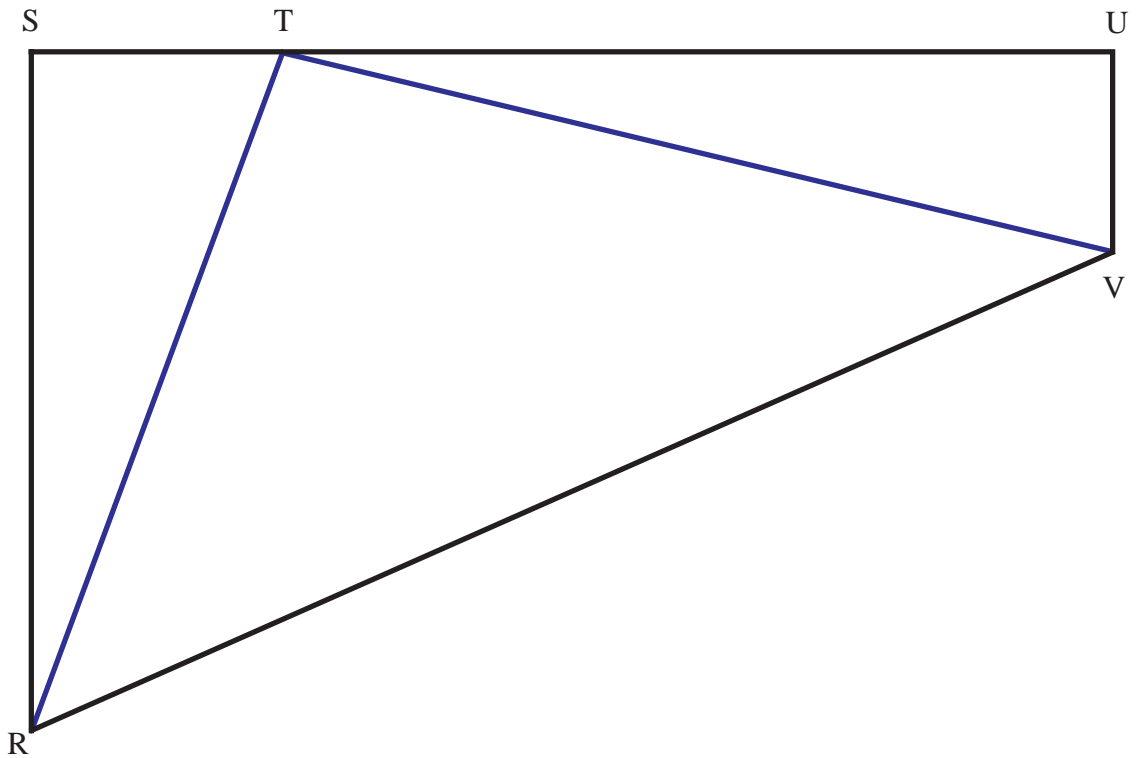

There are two paths in the park. One is labelled TR and the other TV.
A man walks in the park so that he is always the same distance from both paths.
Using ruler and compasses show exactly where the man can walk.

1)

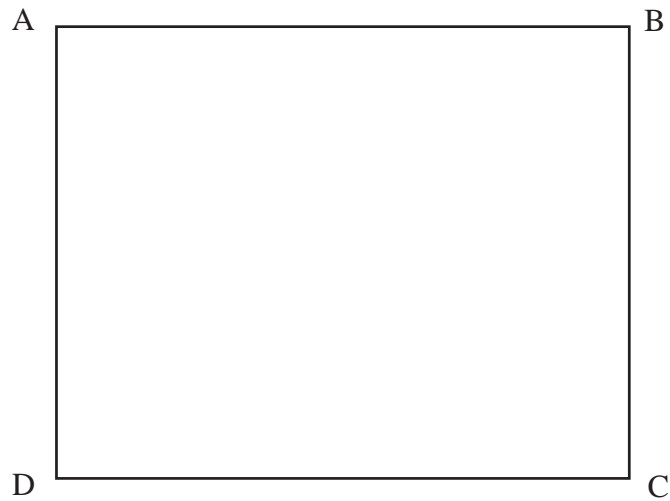

ABCD is a rectangle.

Shade the set of points inside the rectangle which are **both** more than 4 centimetres from the point D **and** more than 1 centimetre from the line AB.

2) Two radio transmitters, A and B, are situated as below.



Transmitter A broadcasts signals which can be heard up to 3 km from A.

Transmitter B broadcasts signals which can be heard up to 6 km from B.

Shade in the area in which radio signals can be heard from both transmitters.

Use a scale of 1 cm = 1 km.

1)

A
×

×

×

C

Point C is equidistant from points A and B.

Sarah rolls a ball from point C.

At any point on its path the ball is the same distance from point A and point B.

- a) On the diagram above draw accurately the path that the ball will take.
- b) On the diagram shade the region that contains all the points that are no more than 3cm from point B.

2) The map shows part of a lake.

In a competition for radio-controlled ducks, participants have to steer their ducks so that:

its path between AB and CD is a straight line

this path is always the same distance from A as from B

- a) On the map, draw the path the ducks should take.

Scale: 1 cm represents 10 m

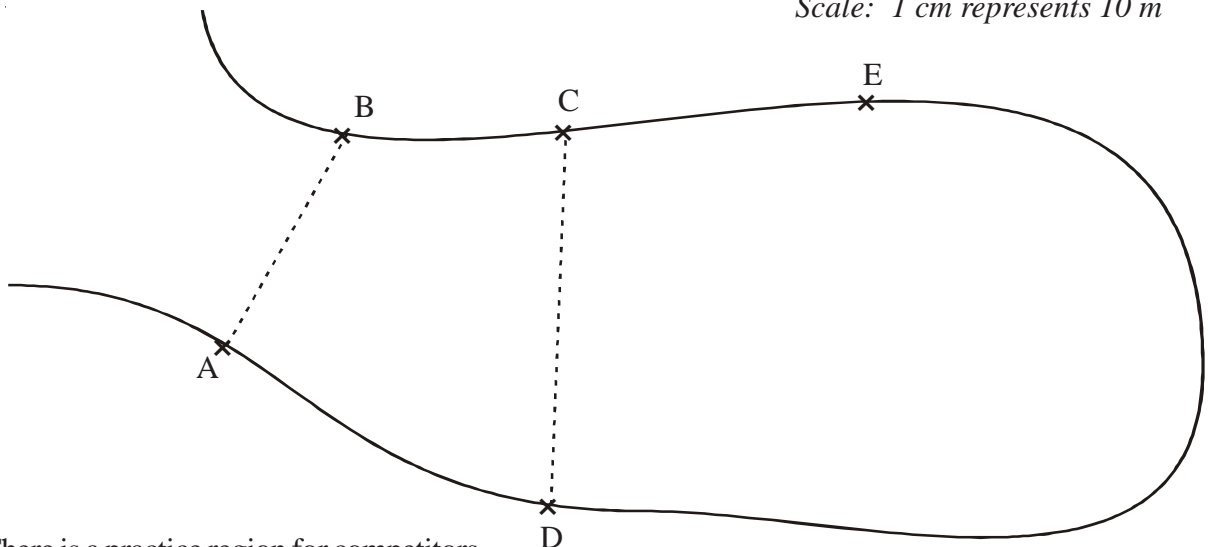

There is a practice region for competitors.

This is the part of the lake which is less than 30 m from point E.

- b) Shade the practice region on the map.

Bearings

- 1) School B is due east of school A.
 C is another school.
 The bearing of C from A is 065° .
 The bearing of C from B is 313° .

Complete the scale drawing below.
 Mark with a cross the position of C.



- 2) In the diagram, point A marks the position of Middlewich.
 The position of Middlemarch is to be marked on the diagram as point B
 On the diagram, mark with a cross the position of B given that:
 B is on a bearing of 320° from A and
 B is 5 cm from A



- 3) **Work out** the bearing of
 a) B from P
 b) P from A

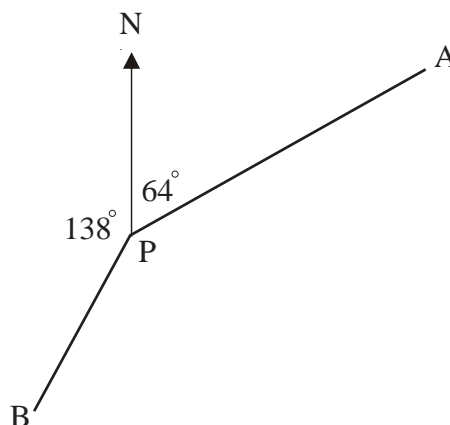

Diagram NOT accurately drawn.

- 1) Ahmad does a statistical experiment.
He throws a dice 600 times.
He scores one, 200 times.
Is the dice fair? Explain your answer

- 2) Chris has a biased coin.
The probability that the biased coin will land on a tail is 0.3
Chris is going to flip the coin 150 times.
Work out an estimate for the number of times the coin will land on a tail.

- 3) On a biased dice, the probability of getting a six is $\frac{2}{3}$.
The dice is rolled 300 times.
Work out an estimate for the number of times the dice will land on a six.

- 4) On a biased dice, the probability of getting a three is 0.5
The dice is rolled 350 times.
Work out an estimate for the number of times the dice will land on a three.

- 5) Jenny throws a biased dice 100 times.
The table shows her results.

Score	Frequency
1	15
2	17
3	10
4	24
5	18
6	16

- a) She throws the dice once more.
Find an estimate for the probability that she will get a four.

- b) If the dice is rolled 250 times, how many times would you expect to get a five?

Averages From a Table

- 1) The number of pens in each pupil's pencil case in a classroom has been counted. The results are displayed in a table.

Number of pens	Number of pupils
0	4
1	6
2	7
3	5
4	3
5	1

- a) Work out the total number of pens in the classroom.
- b) Write down the modal number of pens in a pencil case.
- c) Work out the mean number of pens in a pencil case.
- d) Work out the range of the number of pens in a pencil case.

- 2) Thomas is analysing the local football team. He records the number of goals scored in each football match in the past twelve months.

Thomas said that the mode is 7
Thomas is wrong.

- a) Explain why.
- b) Calculate the mean number of goals scored.

Goals scored	Frequency
0	7
1	5
2	3
3	6
4	2
5	1
6	1

- 3) Tina recorded how long, in minutes, she watched TV for each day during a month.

- a) Find the class interval in which the median lies.
- b) Work out an estimate for the mean amount of time Tina watched TV each day of this month. Give your answer to the nearest minute.

Time (t in minutes)	Frequency
$10 < t \leq 20$	5
$20 < t \leq 30$	9
$30 < t \leq 45$	8
$45 < t \leq 60$	6
$60 < t \leq 90$	3

Questionnaires

- 1) A survey into how people communicate with each other is carried out. A questionnaire is designed and two of the questions used are shown below. The questions are **not** suitable. For each question, write down a reason why.

a) Do you prefer to communicate with your friend by phone (voice call) or by text message?

Yes No

Reason

.....

b) How many text messages do you send?

1 2 3 4

Reason

.....

- 2) A restaurant owner has made some changes. He wants to find out what customers think of these changes. He uses this question on a questionnaire.

“What do you think of the changes in the restaurant?”

 Excellent Very good Good

a) Write down what is wrong with this question.

This is another question on the questionnaire.

“How often do you come to the restaurant?”

 Very often Not often

b) i) Write down one thing that is wrong with this question.

- ii) Design a better question to use. You should include some response boxes.

INDEX

numbers refer to pages, not to clips

A

Addition and subtraction 16
Addition and subtraction of fractions 51
Algebraic simplification 94, 95
Alternate angles 62
Angle sum of triangles 63, 64
Angles - alternate 62
Angles - names of 31
Angles measuring and drawing 74
Angles of regular polygons 65
Area of circles 66
Area of compound shapes 68
Area of rectangles, triangles, parallelograms 33
Averages 41
Averages from a table 126

B

Bearings 124
Bisecting a line 119
Bisecting an angle 121
BODMAS 54
Bounds 117

C

Calculator questions 58
Change a fraction to a decimal 53
Change to a percentage with a calculator 49
Change to a percentage without a calculator 49
Changing the subject of a formula 99
Circles - area of 66
Circles - circumference of 67
Circumference of circles 67
Compound measures 118
Compound shapes - area of 68
Congruent and similar shapes 32
Constructions - bisecting a line 119
Constructions - bisecting an angle 121
Constructions - drawing angles 74
Constructions - drawing nets 77
Constructions - drawing triangles 75
Constructions - perpendicular to a line 120
Constructions - plans and elevations 76
Conversion graphs 43
Converting metric measures 35
Coordinates 28
Coordinates in 3 dimensions 112
Correlation 82
Cube numbers 9
Cube root 45
Cuboids - find the volume of 34
Cuboids - surface area 113

D

Data collection 79
Decimal places and significant figures 20
Decimals - dividing by 92
Decimals - multiplication and division 19
Decimals and percentages 10
Dimensions 116

Distance tables 24
Divide by powers of 10 5
Division 18
Division of fractions 52
Division with decimals 19
Division with negatives 7
Drawing - isometric 39
Drawing a perpendicular to a line 120
Drawing angles 74
Drawing quadratic graphs 108
Drawing straight line graphs 105
Drawing triangles 75

E

Enlargements 71
Equation of a straight line 106
Equations - forming and solving 98
Equations - solving 97
Equivalent fractions 46
Estimate of the mean 126
Estimating answers 93
Estimation 14
Evaluate powers, squares, cubes & roots 45
Expanding and simplifying brackets 94, 95
Experimental probabilities 125

F

Factorisation - simple 96
Factors, multiples and primes 44
Find a percentage with a calculator 48
Find a percentage without a calculator 48
Find the mid-point of a line 73
Finding the equation of a straight line 106
Forming equations 98
Four rules of negatives 92
Fraction of an amount 8, 50
Fraction to a decimal 53
Fractions - adding and subtracting 51
Fractions - change to a decimal 53
Fractions - multiply and divide 52
Fractions - putting in order 46
Fractions - shading 12
Fractions - simplifying 46
Fractions, decimals and percentages 10
Frequency diagrams 83
Frequency polygons 83

G

Graphs - straight lines 105
Graphs - travel graphs 109

H

Half-way values 21
Hard calculator questions 58
Highest common factor 89

INDEX

numbers refer to pages, not to clips

I

Imperial measures 35
Increase/decrease by a percentage 87
Index notation for multiplication and division 103
Indices 26, 45, 90, 103
Inequalities - on a line 100
Inequalities - solving 101
Isometric drawing 39

L

Limits of accuracy - grade C questions 117
Line graphs 27
List of outcomes 85
Loci 122, 123
Long division 18
Long multiplication 17
Long multiplication of decimals 55
Lowest common multiple 89

M

Mean 41
Measuring and drawing angles 74
Median 41
Metric measures 35
Mid-point of a line 73
Mixed numbers 51
Mode 41
Money - value for 47
Money questions - grade D 59
Money questions - grades E to G 11
Multiples 44
Multiplication 17
Multiplication & division with negatives 7
Multiplication and division of fractions 52
Multiplication and division with decimals 19
Multiplication of decimals 55
Multiply and divide by powers of 10 5
Mutually exclusive events 85

N

Names of solids 37
Negatives - four rules of 92
Negatives in real life 6
Nets 77
Nth term 60, 104
Number machines 30
Number sequences 29, 60, 104

O

Ordering fractions 46
Ordering fractions, percentages & decimals 13
Ordering numbers 2
Outcomes - listing 85
Overview of percentages 86

P

Parallelograms - find area and perimeter 33
Patterns - find the nth term 60

Patterns - number 29
Percentages - change by a percentage 87
Percentages - change to, with calculator 49
Percentages - change to, without calculator 49
Percentages - find with calculator 48
Percentages - find without calculator 48
Percentages - mixture of questions 86
Percentages to decimals and fractions 10
Perimeter and areas 33
Perpendicular to a line 120
Pictograms 42
Pie charts 81
Place value 1
Place value when multiplying 15
Planes of symmetry 78
Plans and elevations 76
Polygons - features of 36
Polygons - interior and exterior angles 65
Powers 26, 45, 103
Prime factors 89
Primes 44
Prisms 114
Probability - experimental 125
Probability - mutually exclusive events 85
Probability scale 40
Product of prime factors 89
Proportion 23
Pythagoras 110
Pythagoras - line on a graph 111

Q

Quadratic graphs 108
Quadrilaterals 36
Questionnaires 127
Questionnaires and data collection 79

R

Range 41
Ratio 56, 88
Ratio - recipe questions 57
Reading scales 4
Real-life graphs 109
Real-life money questions 59
Recipe type ratio questions 57
Reciprocals 22
Rectangles - find area and perimeter 33
Recurring decimals into fractions 91
Reflections 70
Roots 45
Rotational symmetry 78
Rotations 69
Rounding 3

S

Scatter graphs 82
Sequences 29
Shading fractions 12
Significant figures 20
Similar shapes 32, 115

INDEX

numbers refer to pages, not to clips

Simplifying algebraic expressions 94
Simplifying and ordering fractions 46
Simplifying brackets 95
Simultaneous equations graphically 107
Solids 37
Solving equations 97
Solving inequalities 101
Solving simultaneous equations graphically 107
Square and cube numbers 9
Square roots 45
Squares, cubes & roots 45
Standard form - changing to, etc 90
Stem and leaf diagrams 84
Straight line graphs - drawing 105
Straight line graphs - finding the equation 106
Subject of a formula 99
Substitution 61
Surface area of cuboids 113
Symmetries 78

T

Tessellations 38
Timetables 25
Transformation - enlargement 71
Transformation - reflection 70
Transformation - rotation 69
Transformation - translation 72
Translations 72
Trial and improvement 102
Triangles - find area and perimeter 33
Triangles, quadrilaterals, polygons 36
Two-way tables 80

U

Units of measurement 35
Upper and lower bounds 117

V

Value for money 47
Volume of a prism 114
Volume of cuboids 34

Y

$Y = mx + c$ 106